

S.O.ERRE



T° CONTROL
N°3 2017



INDEX



Ventilation



RCQ 50.11 **10**
110×110 mm



RC 12.13 **11**
130×140 mm



RCQ 160.15 **12**
150×150 mm



RC 14.25 **14**
250×250 mm



RCQ 370.25 **15**
250×250 mm



RCQ 160.25 **16**
250×250 mm



RCQ 14.32 **17**
320×320 mm



RC 20.32 **18**
320×320 mm



RC 20.32 S **19**
320×320 mm



RC 20.32 SP **20**
320×320 mm



SYSTEMA **21**



GRILLES & FILTERS **22**
RC - RCS - RCQ SERIES



RQ SERIES **24**

Airing

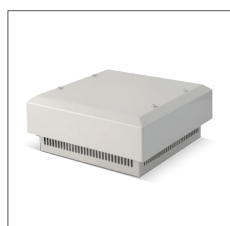

TXQ 550 **26**



TXQ M 550 **27**



TXQ M 860 **28**



TXQ M 1500 **29**



TXQ M 2300 **30**



Conditioning



AC EM **32**
Wall air conditioners

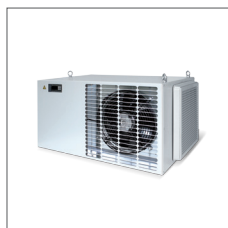

AC RM **35**
Roof air conditioners



HEX WA **38**
Air/water exchanger

Anti-condensation



HE **40**
Anti-condensation heaters



HEV **41**
Anti-condensation ventilated heaters

Accessories



TMS - TMS NC - TMS NO **44**
Thermostats



TMS D **45**
Dual Thermostat



HYM **46**
Hygostat



PW **47**
Pocket wallet



FCL **48**
Fluorescent lamps

ALPHABETICAL INDEX

A		RC 20.32.....	18
AC EM	32	RC 20.32 S	19
AC RM.....	35	RC 20.32 SP.....	20
		RCQ 160.15	12
F		RCQ 160.25	16
FCL.....	48	RCQ 370.25.....	15
		RCQ 50.11.....	10
G			
GRILLES AND FILTERS	22	S	
		RQ SERIES	24
H		SYSTEMA.....	21
HE	40		
HEV	41	T	
HEX WA	38	TMS	44
HYM.....	46	TMS D	45
		TMS NC	44
P		TMS NO	44
PW	47	TXQ 550	26
		TXQ M 550.....	27
R		TXQ M 860.....	28
RC 12.13	11	TXQ M 1500	29
RC 14.25	14	TXQ M 2300.....	30
RC 14.32	17		

TECHNICAL GUIDE

THE TEMPERATURE OF PANELS

The power dissipated by electronic devices produces heat that builds up inside cabinets and switchboards.

By considering also humidity problem, it's even easier to understand the importance of adopting an inside temperature control system.

Operating temperatures and humidity are the main responsible variables for the aging process of internal components. For instance, they alter components' performances (with locks and costly inefficiencies) therefore decreasing durability and reliability.

Environment, type and units quantities are the basic factors used to select the most suitable thermal control system.

O. Erre has always paid great attention to business issues in the aero-thermal field and has further expanded its line by creating T ° Control: a product line dedicated to thermal control switchboards.

VENTILATION

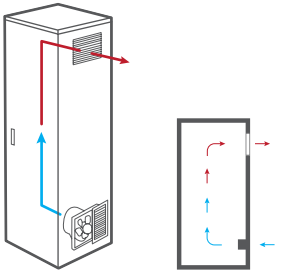

COOLING - FORCED AIR VENTILATION

Forced ventilation allows a quick and efficient disposal of heat dissipated from the components through air exchange inside cabinets. Fan systems are composed of a fan, equipped with grille and filter, combined with a grille for air exhaust which provides the simplest, fastest and cheapest way to reduce the temperature inside the electrical cabinet. The fan is installed at the bottom of the cabinet, filtering and intaking air, the hot air is expelled through another grille, placed on the top of the cabinet, creating a through exchange of air, a proper ventilation allows to achieve an effective heat dissipation. In addition, pressure generated by the ventilation prevents the entrance of non-filtered air from holes or cracks.

AIRING

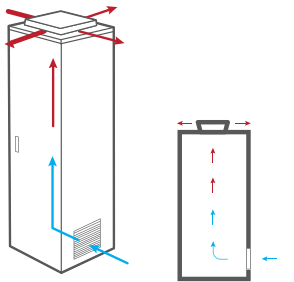

COOLING - FORCED AIR EXTRACTION

When an electrical panel has to extract a significant amount of heat and / or it's not possible to install fans on the side walls forced ventilation can be achieved by installing roof extractors (towers) and one or more grilles with filter for air intake filter with air inlets positioned at the bottom.

The main feature of the ventilation towers is its high airflow.

The vacuum generated by the tower installed on top of the cabinet, draws outside air installed at the bottom of the grille, thus realizing the exchange of the air volume inside and consequent heat dissipation.

CONDITIONING

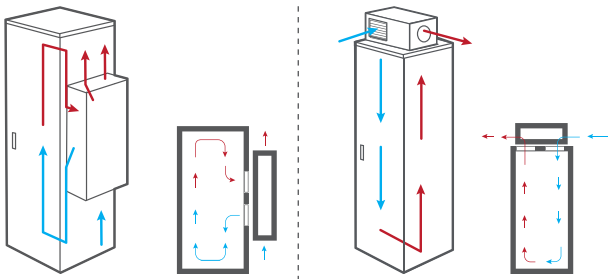

AIR CONDITIONERS

The cooling devices allow to achieve a lower temperature inside cabinet and at the same time keeping internal and external environments separated.

This is their main use. So, when the outside temperature is high (and therefore not suitable to dissipate heat by ventilation) and it is necessary to keep internal environment separated by the external one, the air conditioning system is the most suitable solution.

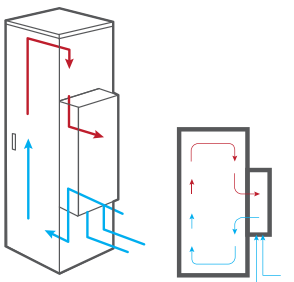

AIR/WATER EXCHANGER

The air-water heat exchangers control cabinet allow to keep constant temperature inside cabinet through action of cool water deriving by water circuit. They are suitable in environments where a high degree of protection (presence of water jets, conductive dust) inside cabinet, is required.

ANTI-CONDENSATION

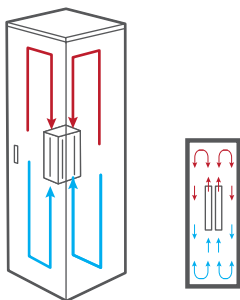

SOMETIMES IS BETTER TO WARM UP..

The heaters prevent condensation and keep minimum temperature inside cabinet while ensuring the proper operation of all the other components installed.

T° VENTILATION



COOLING FORCED
AIR VENTILATION

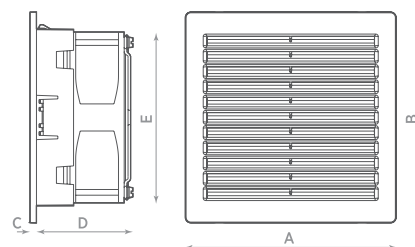

Model	A	B	C	D	E
RCQ 50.11	110	110	4,5	61	80

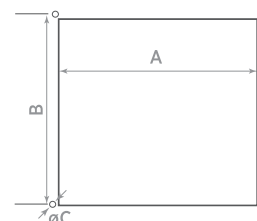

Drilling scheme	A	B	Ø C
RCQ 50.11	92x92	95x95	2,6

RCQ 50.11 - 110×110 | 35 m³/h

VENTILATION

- Axial fans supplied with grille and filter;
- Low external profile;
- IP54 protection degree (IP44 on request);
- Maximum operating temperature: +70°C;
- Quick and functional assembly of the fan on the electrical cabinet through elastic click hooks and gasket pre-installed on the product;
- Possible installation with screws (not provided);

- Body and Grille made of ABS self-extinguishing material grey RAL 7035;
- Ball bearing motor;
- Easily removable grille to allow quick replacement of the filter;
- Slotted external grilles to allow drainage of condensation;
- In accordance with European Standard EN 60529, EN 60335-2-80;
- UL version available.

TECHNICAL DATA

Model intake	Code	Model extraction	Code	IP Grade	Voltage (V)	Frequency (Hz)	Colour grille	Flow rate (m ³ /h) with filter	Flow rate (m ³ /h) without filter	Power (W)	Nom. Curr. (A)	Noisiness dB(A) _{3m}	Weight Kg
RCQ 50.11	0104535	RCQ 50.11 E	0104935	IP54	12	-	GREY RAL 7035	25	35	3	0,15	30	0,2
RCQ 50.11	0104635	RCQ 50.11 E	0105035	IP54	24	-	GREY RAL 7035	25	35	3	0,08	30	0,2
RCQ 50.11	0104735	RCQ 50.11 E	0105135	IP54	110-120	50/60	GREY RAL 7035	25	35	9	0,12	32	0,4
RCQ 50.11	0104835	RCQ 50.11 E	0105235	IP54	220-240	50/60	GREY RAL 7035	25	35	9	0,06	32	0,4
RCQ 50.11 UL	0204535	RCQ 50.11 E UL	0204935	IP54	12	-	GREY RAL 7035	25	35	3	0,15	30	0,2
RCQ 50.11 UL	0204635	RCQ 50.11 E UL	0205035	IP54	24	-	GREY RAL 7035	25	35	3	0,08	30	0,2
RCQ 50.11 UL	0204735	RCQ 50.11 E UL	0205135	IP54	110-120	50/60	GREY RAL 7035	25	35	9	0,12	32	0,4
RCQ 50.11 UL	0204835	RCQ 50.11 E UL	0205235	IP54	220-240	50/60	GREY RAL 7035	25	35	9	0,06	32	0,4

FLOW CHARTS

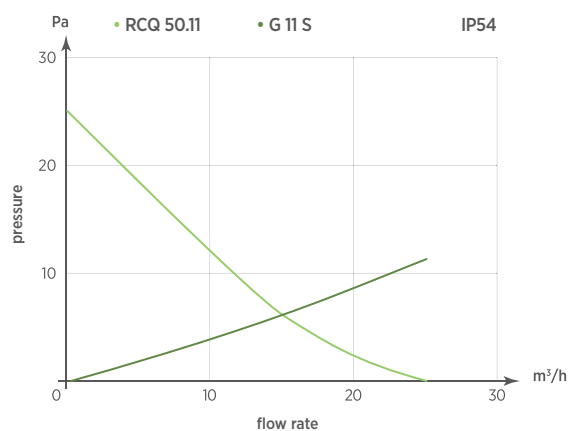

ACCESSORIES: SEE PAGES 22 AND 44



Grilles



Thermostats



Hygrostat

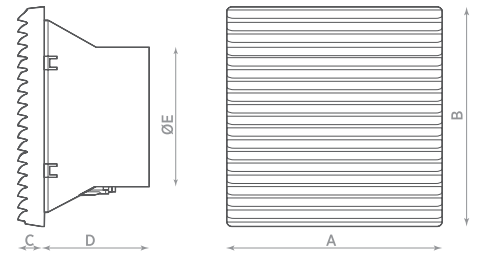

Model	A	B	C	D	ØE
RCQ 50.11	130	140	24	74	114

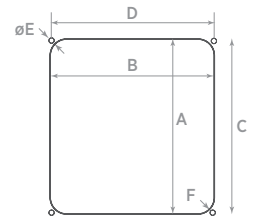

Drilling scheme	A	B	C	D	ØE	F
RC 12.13	117	125	115	123	3	12

RC 12.13 - 130×140 | 67 m³/h

VENTILATION

- Axial fans supplied with grille and filter;
- High external profile;
- IP44 or IP54 protection degree;
- Quick and functional assembly of the fan on the electrical cabinet through elastic click hooks and gasket pre-installed on the product;
- Maximum operating temperature: +50°C;
- Electrical connection through terminal block;

- Possible installation with screws (provided);
- Ball bearing motor;
- Body made of ABS self-extinguishing material grey RAL 7035;
- Grilles in grey RAL 7032 and 7035, black RAL 9005;
- Easily removable grille to allow quick replacement of the filter;
- Slotted external grilles to allow drainage of condensation;
- In accordance with European Standard EN 60529, EN 60335-2-80.

TECHNICAL DATA

Model intake	Code	IP Grade	Voltage (V)	Frequency (Hz)	Colour grille	Flow rate (m ³ /h) with filter	Flow rate (m ³ /h) without filter	Power (W)	Nom. Curr. (A)	Noisiness dB(A) _{1m}	Weight Kg
RC 12.13	0095532	IP44	220-240	50/60	GREY RAL 7032	50	67	17	0,11	38	0,6
RC 12.13	0095535	IP44	220-240	50/60	GREY RAL 7035	50	67	17	0,11	38	0,6
RC 12.13	0095505	IP44	220-240	50/60	BLACK RAL 9005	50	67	17	0,11	38	0,6
RC 12.13	0095932	IP44	110-120	50/60	GREY RAL 7032	50	67	17	0,22	38	0,6
RC 12.13	0095935	IP44	110-120	50/60	GREY RAL 7035	50	67	17	0,22	38	0,6
RC 12.13	0095905	IP44	110-120	50/60	BLACK RAL 9005	50	67	17	0,22	38	0,6
RC 12.13	0090132	IP54	220-240	50/60	GREY RAL 7032	30	67	17	0,11	38	0,6
RC 12.13	0090135	IP54	220-240	50/60	GREY RAL 7035	30	67	17	0,11	38	0,6
RC 12.13	0090105	IP54	220-240	50/60	BLACK RAL 9005	30	67	17	0,11	38	0,6
RC 12.13	0090032	IP54	110-120	50/60	GREY RAL 7032	30	67	17	0,22	38	0,6
RC 12.13	0090035	IP54	110-120	50/60	GREY RAL 7035	30	67	17	0,22	38	0,6
RC 12.13	0090005	IP54	110-120	50/60	BLACK RAL 9005	30	67	17	0,22	38	0,6

FLOW CHARTS

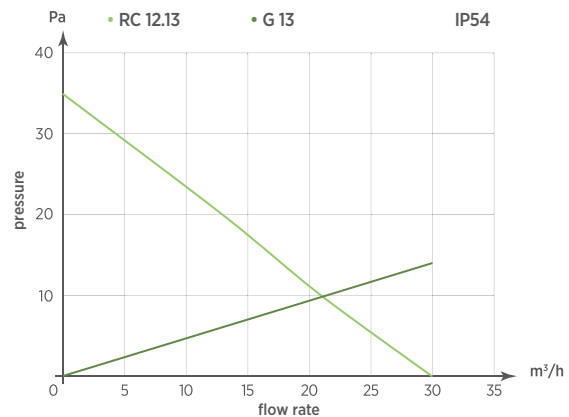
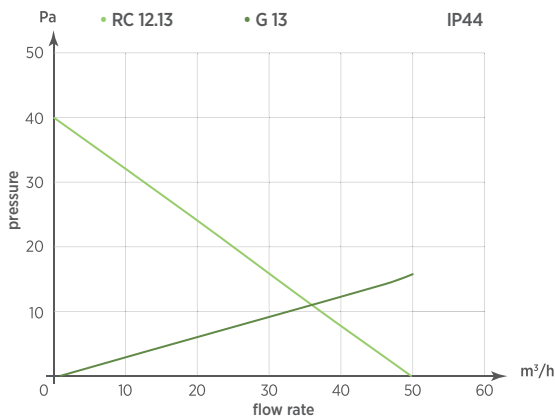

ACCESSORIES: SEE PAGE 22 AND 44



Grilles



Thermostats



Hygostat

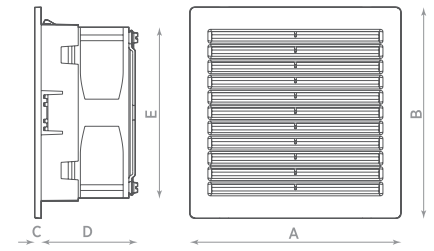

Model	A	B	C	D	E
RCQ 160.15	148	148	5	68	120

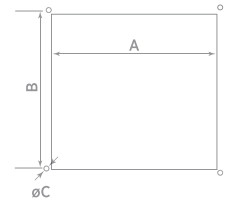

Drilling scheme	A	B	Ø C
RCQ 160.15	125×125	131×131	4,5

RCQ 160.15 - 150×150 | 120 m³/h

VENTILATION

- Axial fans supplied with grille and filter;
- Low external profile;
- IP55 or IP54 Protection degree (IP44 on request);
- Maximum operating temperature: +70° C;
- Quick and functional assembly of the fan of the electrical cabinet through elastic click hooks and gasket pre-installed on the product;
- Possible installation with screws (not provided);

- Body and Grille made of ABS self-extinguishing material grey RAL 7035;
- Ball bearing motor;
- Slotted external grilles to allow drainage of condensation;
- Easily removable grille to allow quick replacement of the filter;
- In accordance with European Standard EN 60529, EN 60335-2-80;
- UL version available.

TECHNICAL DATA

Model intake	Code	Model extraction	Code	IP Grade	Voltage (V)	Frequency (Hz)	Colour grille	Flow rate (m ³ /h) with filter	Flow rate (m ³ /h) without filter	Power (W)	Nom. Curr. (A)	Noisiness dB(A) _{1m}	Weight Kg
RCQ 160.15	0100335	RCQ 160.15 E	0101635	IP54	12	-	GREY RAL 7035	55	120	5	0,4	37	0,5
RCQ 160.15	0100435	RCQ 160.15 E	0101735	IP54	24	-	GREY RAL 7035	55	120	5	0,2	37	0,5
RCQ 160.15	0105335	RCQ 160.15 E	0105535	IP54	12	50/60	GREY RAL 7035	60	110	17	2	40	0,75
RCQ 160.15	0104335	RCQ 160.15 E	0104435	IP54	24	50/60	GREY RAL 7035	60	110	15	1	40	0,75
RCQ 160.15	0105435	RCQ 160.15 E	0105635	IP54	48	50/60	GREY RAL 7035	60	110	16	0,5	40	0,75
RCQ 160.15	0100235	RCQ 160.15 E	0101835	IP54	110-120	50/60	GREY RAL 7035	60	110	20	0,25	40	0,75
RCQ 160.15	0100135	RCQ 160.15 E	0101935	IP54	220-240	50/60	GREY RAL 7035	60	110	20	0,125	40	0,75
RCQ 160.15	0100355	-	-	IP55	12	-	GREY RAL 7035	51	120	5	0,4	37	0,5
RCQ 160.15	0100455	-	-	IP55	24	-	GREY RAL 7035	51	120	5	0,2	37	0,5
RCQ 160.15	0100755	-	-	IP55	12	50/60	GREY RAL 7035	56	110	17	2	40	0,75
RCQ 160.15	0100855	-	-	IP55	24	50/60	GREY RAL 7035	56	110	15	1	40	0,75
RCQ 160.15	0101155	-	-	IP55	48	50/60	GREY RAL 7035	56	110	16	0,5	40	0,75
RCQ 160.15	0100255	-	-	IP55	110-120	50/60	GREY RAL 7035	56	110	20	0,25	40	0,75
RCQ 160.15	0100155	-	-	IP55	220-230	50/60	GREY RAL 7035	56	110	20	0,125	40	0,75
RCQ 160.15 UL	0200335	RCQ 160.15 E UL	0201635	IP54	12	-	GREY RAL 7035	55	120	5	0,4	37	0,5
RCQ 160.15 UL	0200435	RCQ 160.15 E UL	0201735	IP54	24	-	GREY RAL 7035	55	120	5	0,2	37	0,5
RCQ 160.15 UL	0205335	RCQ 160.15 E UL	0205535	IP54	12	50/60	GREY RAL 7035	60	110	17	2	40	0,75
RCQ 160.15 UL	0204335	RCQ 160.15 E UL	0204435	IP54	24	50/60	GREY RAL 7035	60	110	15	1	40	0,75
RCQ 160.15 UL	0205435	RCQ 160.15 E UL	0205635	IP54	48	50/60	GREY RAL 7035	60	110	16	0,5	40	0,75
RCQ 160.15 UL	0200235	RCQ 160.15 E UL	0201835	IP54	110-120	50/60	GREY RAL 7035	60	110	20	0,25	40	0,75
RCQ 160.15 UL	0200135	RCQ 160.15 E UL	0201935	IP54	220-240	50/60	GREY RAL 7035	60	110	20	0,125	40	0,75
RCQ 160.15 UL	0200355	-	-	IP55	12	-	GREY RAL 7035	51	120	5	0,4	37	0,5
RCQ 160.15 UL	0200455	-	-	IP55	24	-	GREY RAL 7035	51	120	5	0,2	37	0,5
RCQ 160.15 UL	0200755	-	-	IP55	12	50/60	GREY RAL 7035	56	110	17	2	40	0,75
RCQ 160.15 UL	0200855	-	-	IP55	24	50/60	GREY RAL 7035	56	110	15	1	40	0,75
RCQ 160.15 UL	0201155	-	-	IP55	48	50/60	GREY RAL 7035	56	110	16	0,5	40	0,75
RCQ 160.15 UL	0200255	-	-	IP55	110-120	50/60	GREY RAL 7035	56	110	20	0,25	40	0,75
RCQ 160.15 UL	0200155	-	-	IP55	220-240	50/60	GREY RAL 7035	56	110	20	0,125	40	0,75

FLOW CHARTS

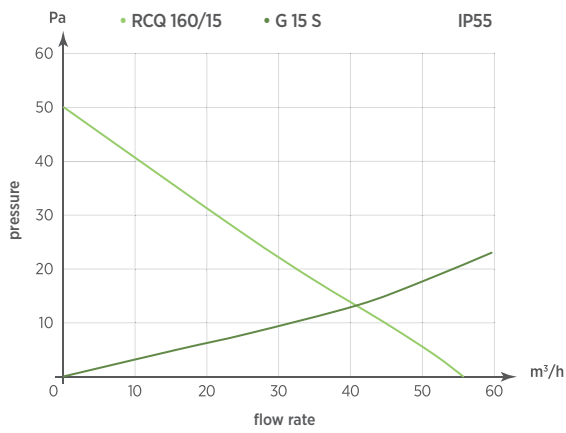
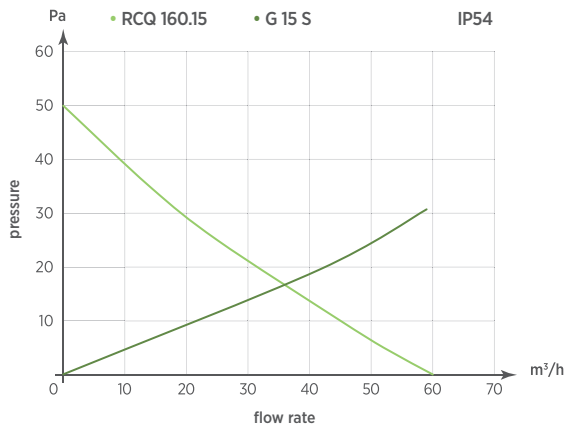

ACCESSORIES: SEE PAGES 22 AND 44



Grilles



Thermostats



Hygrostat

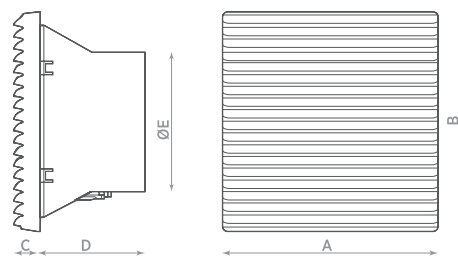

Model	A	B	C	D	ØE
RC 14.25	256	256	29	91	147

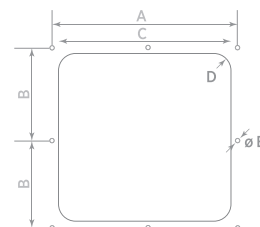

Drilling scheme	A	B	C	D	ØE
RC 14.25	232	116	220	15	3,5

RC 14.25 - 250×250 | 250 m³/h

VENTILATION

- Axial fans supplied with grille and filter;
- High external profile;
- IP44 or IP54 protection degree;
- Quick and functional assembly of the fan on the electrical cabinet through elastic click hooks and gasket pre-installed on the product;
- Slotted external grilles to allow drainage of condensation;
- Maximum operating temperature: +50°C;

- Possible installation with screws (provided);
- Electrical connection through terminal block;
- Ball bearing motor;
- Body made of ABS self-extinguishing material grey RAL 7035;
- Grilles in grey RAL 7032 and 7035, black RAL 9005;
- Easily removable grille to allow quick replacement of the filter;
- In accordance with European Standard EN 60529,

TECHNICAL DATA

Model intake	Code	IP Grade	Voltage (V)	Frequency (Hz)	Colour grille	Flow rate (m³/h) with filter	Flow rate (m³/h) without filter	Power (W)	Nom. Curr. (A)	Noisiness dB(A) _{5m}	Weight Kg
RC 14.25	0090332	IP44	220-240	50/60	GREY RAL 7032	150	250	30	0,22	40	1,2
RC 14.25	0090335	IP44	220-240	50/60	GREY RAL 7035	150	250	30	0,22	40	1,2
RC 14.25	0090305	IP44	220-240	50/60	BLACK RAL 9005	150	250	30	0,22	40	1,2
RC 14.25	0090232	IP44	110-120	50/60	GREY RAL 7032	150	250	30	0,44	40	1,2
RC 14.25	0090235	IP44	110-120	50/60	GREY RAL 7035	150	250	30	0,44	40	1,2
RC 14.25	0090205	IP44	110-120	50/60	BLACK RAL 9005	150	250	30	0,44	40	1,2
RC 14.25	0090632	IP54	220-240	50/60	GREY RAL 7032	130	250	30	0,22	40	1,2
RC 14.25	0090635	IP54	220-240	50/60	GREY RAL 7035	130	250	30	0,22	40	1,2
RC 14.25	0090605	IP54	220-240	50/60	BLACK RAL 9005	130	250	30	0,22	40	1,2
RC 14.25	0090432	IP54	110-120	50/60	GREY RAL 7032	130	250	30	0,44	40	1,2
RC 14.25	0090435	IP54	110-120	50/60	GREY RAL 7035	130	250	30	0,44	40	1,2
RC 14.25	0090405	IP54	110-120	50/60	BLACK RAL 9005	130	250	30	0,44	40	1,2

FLOW CHARTS

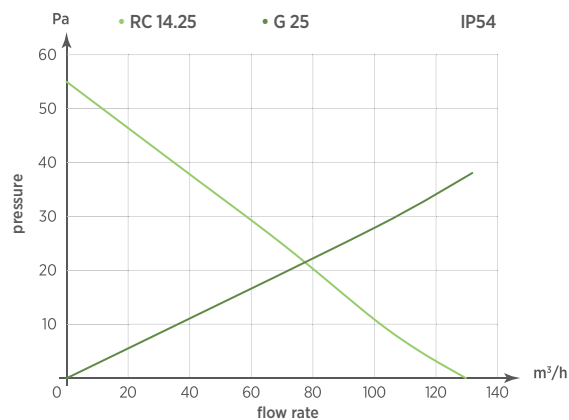
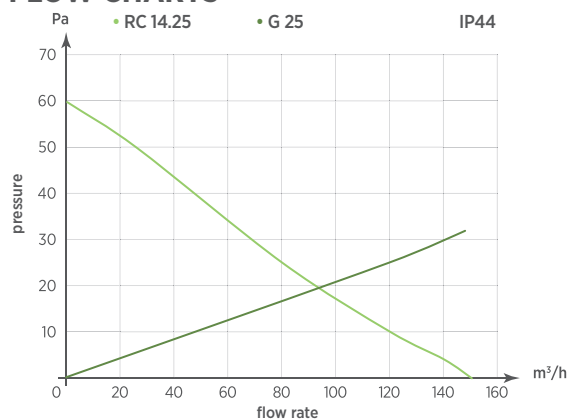

ACCESSORIES: SEE PAGES 22 AND 44



Grilles



Thermostats



Hygostat

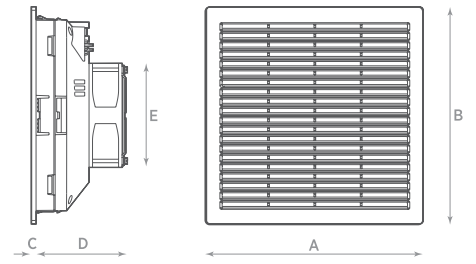

Model	A	B	C	D	ØE
RCQ 370.25	250	250	5,5	118	152x172

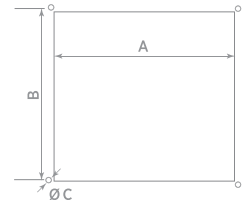

Drilling scheme	A	B	Ø C
RCQ 370.25	223x223	230÷234x230÷234	4,5

RC 370.25 - 250x250 | 300 m³/h

VENTILATION

- Axial fans supplied with grille and filter;
- Low external profile;
- IP54 protection degree (IP44 on request);
- Maximum operating temperature: +70°C;
- Quick and functional assembly of the fan on the electrical cabinet through elastic click hooks and gasket pre-installed on the product;
- Possible installation with screws (not provided);

- Body and Grille made of ABS self-extinguishing material grey RAL 7035;
- Ball bearing motor;
- Slotted external grilles to allow drainage of condensation;
- Easily removable grille to allow quick replacement of the filter;
- In accordance with European Standard EN 60529, EN 60335-2-80;
- UL version available.

TECHNICAL DATA

Model intake	Code	Model extraction	Code	IP Grade	Voltage (V)	Frequency (Hz)	Colour grille	Flow rate (m ³ /h) with filter	Flow rate (m ³ /h) without filter	Power (W)	Nom. Curr. (A)	Noisiness dB(A) _{5m}	Weight Kg
RCQ 370.25	0101135	RCQ 370.25 E	0102435	IP54	12	-	GREY RAL 7035	220	260	9	0,86	50	1,5
RCQ 370.25	0101235	RCQ 370.25 E	0102535	IP54	24	-	GREY RAL 7035	220	260	9	0,43	50	1,5
RCQ 370.25	0106535	RCQ 370.25 E	0106635	IP54	48	-	GREY RAL 7035	220	260	13	0,28	50	1,5
RCQ 370.25	0101035	RCQ 370.25 E	0102635	IP54	110-120	50/60	GREY RAL 7035	260	300	25	0,22	50	1,6
RCQ 370.25	0100935	RCQ 370.25 E	0102735	IP54	220-240	50/60	GREY RAL 7035	260	300	25	0,11	50	1,6
RCQ 370.25 UL	0201035	RCQ 370.25 E UL	0202635	IP54	110-120	50/60	GREY RAL 7035	260	300	25	0,22	50	1,6
RCQ 370.25 UL	0200935	RCQ 370.25 E UL	0202735	IP54	220-240	50/60	GREY RAL 7035	260	300	25	0,11	50	1,6

FLOW CHARTS

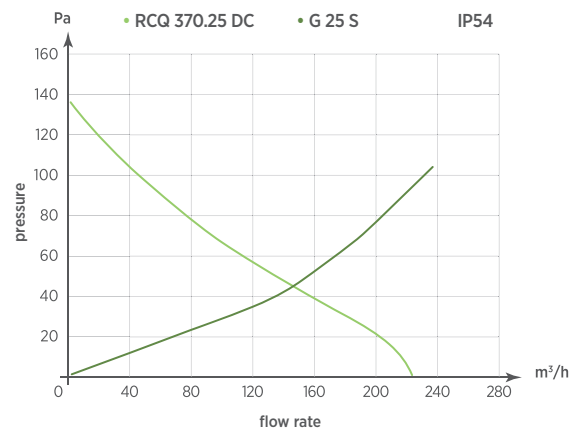
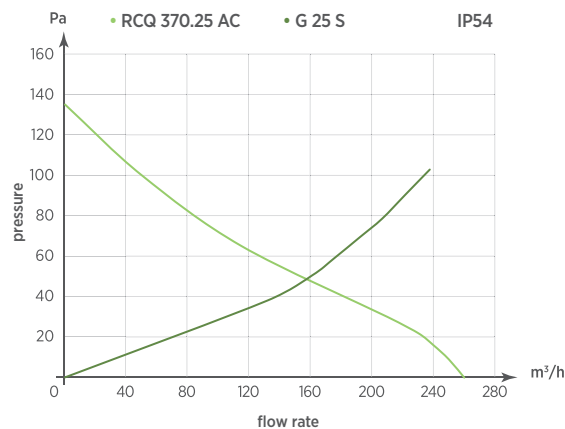

ACCESSORIES: SEE PAGES 22 AND 44



Grilles



Thermostats



Hygrostat

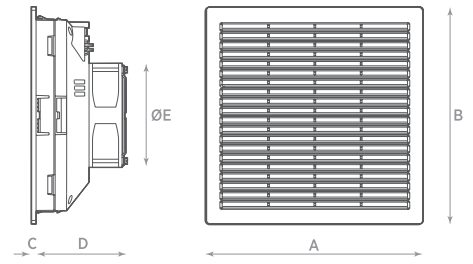

Model	A	B	C	D	ØE
RCQ 160.25	250	250	5,5	105	120

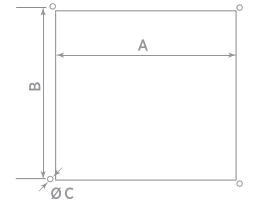

Drilling scheme	A	B	C
RCQ 160.25	223x223	230=234x230+234	4,5

RCQ 160.25 - 250x250 | 145 m³/h

VENTILATION

- Axial fans supplied with grille and filter;
- Low external profile;
- IP54 protection degree (IP44 on request);
- Maximum operating temperature: +70°C;
- Quick and functional assembly of the fan on the electrical cabinet through elastic click hooks and gasket pre-installed on the product;
- Possible installation with screws (not provided);

- Body and Grille made of ABS self-extinguishing material grey RAL 7035;
- Ball bearing motor;
- Slotted external grilles to allow drainage of condensation;
- Easily removable grille to allow quick replacement of the filter;
- In accordance with European Standard EN 60529, EN 60335-2-80;
- UL version available.

TECHNICAL DATA

Model intake	Code	Model extraction	Code	IP Grade	Voltage (V)	Frequency (Hz)	Colour grille	Flow rate (m³/h) with filter	Flow rate (m³/h) without filter	Power (W)	Nom. Curr. (A)	Noisiness dB(A) _{2m}	Weight Kg
RCQ 160.25	0100735	RCQ 160.25 E	0102035	IP54	12	-	GREY RAL 7035	120	145	5	0,4	37	0,9
RCQ 160.25	0100835	RCQ 160.25 E	0102135	IP54	24	-	GREY RAL 7035	120	145	5	0,2	37	0,9
RCQ 160.25	0105735	RCQ 160.25 E	0106035	IP54	12	50/60	GREY RAL 7035	125	135	17	2	39	0,9
RCQ 160.25	0105835	RCQ 160.25 E	0106135	IP54	24	50/60	GREY RAL 7035	125	135	15	1	39	0,9
RCQ 160.25	0105935	RCQ 160.25 E	0106235	IP54	48	50/60	GREY RAL 7035	125	135	16	0,5	39	0,9
RCQ 160.25	0100635	RCQ 160.25 E	0102235	IP54	110-120	50/60	GREY RAL 7035	125	135	20	0,25	39	1,2
RCQ 160.25	0100535	RCQ 160.25 E	0102335	IP54	220-240	50/60	GREY RAL 7035	125	135	20	0,125	39	1,2
RCQ 160.25 UL	0200735	RCQ 160.25 E UL	0202035	IP54	12	-	GREY RAL 7035	120	145	5	0,4	37	0,9
RCQ 160.25 UL	0200835	RCQ 160.25 E UL	0202135	IP54	24	-	GREY RAL 7035	120	145	5	0,2	37	0,9
RCQ 160.25 UL	0205735	RCQ 160.25 E UL	0206035	IP54	12	50/60	GREY RAL 7035	125	135	17	2	39	0,9
RCQ 160.25 UL	0205835	RCQ 160.25 E UL	0206135	IP54	24	50/60	GREY RAL 7035	125	135	15	1	39	0,9
RCQ 160.25 UL	0205935	RCQ 160.25 E UL	0206235	IP54	48	50/60	GREY RAL 7035	125	135	16	0,5	39	0,9
RCQ 160.25 UL	0200635	RCQ 160.25 E UL	0202235	IP54	110-120	50/60	GREY RAL 7035	125	135	20	0,25	39	1,2
RCQ 160.25 UL	0200535	RCQ 160.25 E UL	0202335	IP54	220-240	50/60	GREY RAL 7035	125	135	20	0,125	39	1,2

FLOW CHARTS

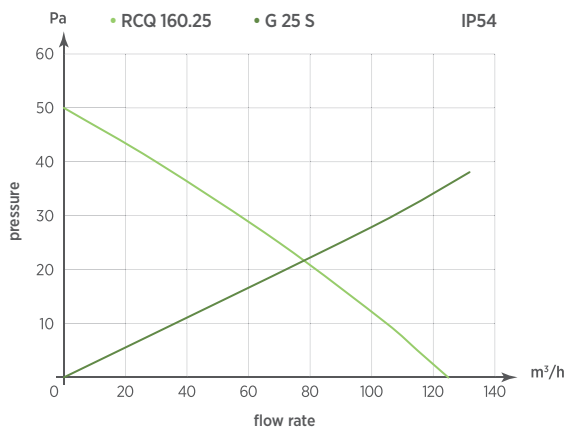

ACCESSORIES:

SEE PAGES 22 AND 44



Grilles



Thermostats



Hygostat

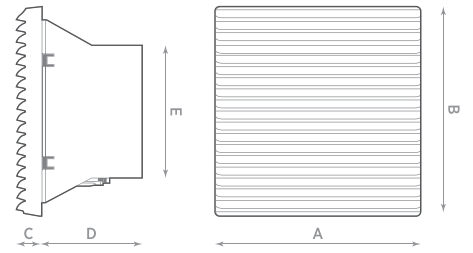

Model	A	B	C	D	ØE
RC 14.32	323	322	34	145	147

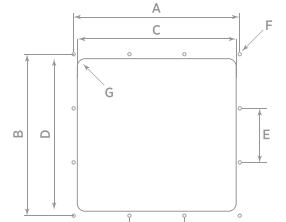

Drilling scheme	A	B	C	D	E	ØF	G (r)
RC 14.32	302	297	287	281	100	3,5	12,5

RC 14.32 - 320×320 | 270 m³/h

VENTILATION

- Axial fans supplied with grille and filter;
- High external profile;
- IP44 or IP54 protection degree;
- Quick and functional assembly of the fan on the electrical cabinet through elastic click hooks and gasket pre-installed on the product;
- Maximum operating temperature: +50°C;
- Possible installation with screws (provided);

- Slotted external grilles to allow drainage of condensation;
- Electrical connection through terminal block;
- Ball bearing motor;
- Body made of ABS self-extinguishing material grey RAL 7035;
- Grilles in grey RAL 7032 and 7035, black RAL 9005;
- Easily removable grille to allow quick replacement of the filter;
- In accordance with European Standard EN 60529, EN 60335-2-80.

TECHNICAL DATA

Model intake	Code	IP Grade	Voltage (V)	Frequency (Hz)	Colour grille	Flow rate (m³/h) with filter	Flow rate (m³/h) without filter	Power (W)	Nom. Curr. (A)	Noisiness dB(A) _{2m}	Weight Kg
RC 14.32	0097132	IP44	220-240	50/60	GREY RAL 7032	180	270	30	0,22	39	1,6
RC 14.32	0097135	IP44	220-240	50/60	GREY RAL 7035	180	270	30	0,22	39	1,6
RC 14.32	0097105	IP44	220-240	50/60	BLACK RAL 9005	180	270	30	0,22	39	1,6
RC 14.32	0097232	IP44	110-120	50/60	GREY RAL 7032	180	270	30	0,44	39	1,6
RC 14.32	0097235	IP44	110-120	50/60	GREY RAL 7035	180	270	30	0,44	39	1,6
RC 14.32	0097205	IP44	110-120	50/60	BLACK RAL 9005	180	270	30	0,44	39	1,6
RC 14.32	0089432	IP54	220-240	50/60	GREY RAL 7032	150	270	30	0,22	39	1,6
RC 14.32	0089435	IP54	220-240	50/60	GREY RAL 7035	150	270	30	0,22	39	1,6
RC 14.32	0089405	IP54	220-240	50/60	BLACK RAL 9005	150	270	30	0,22	39	1,6
RC 14.32	0089332	IP54	110-120	50/60	GREY RAL 7032	150	270	30	0,44	39	1,6
RC 14.32	0089335	IP54	110-120	50/60	GREY RAL 7035	150	270	30	0,44	39	1,6
RC 14.32	0089305	IP54	110-120	50/60	BLACK RAL 9005	150	270	30	0,44	39	1,6

FLOW CHARTS

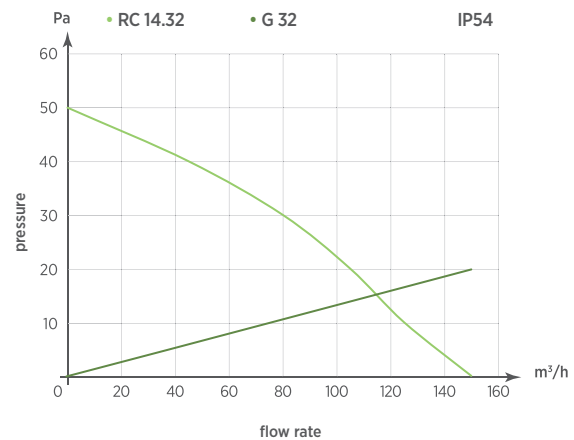
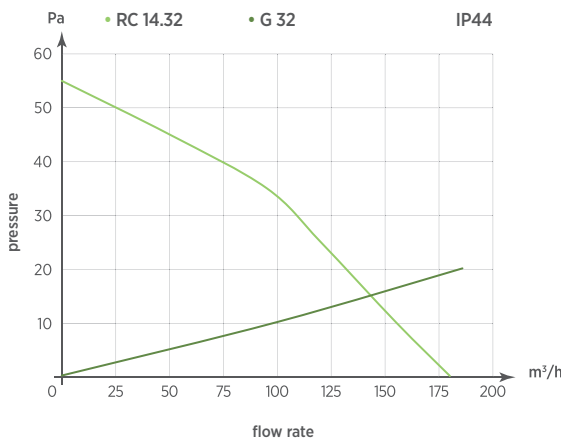

ACCESSORIES:

SEE PAGES 22 AND 44



Grilles



Thermostats



Hygostat

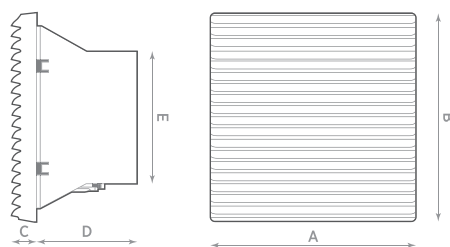

Model	A	B	C	D	ØE
RC 20.32	323	322	34	140	204

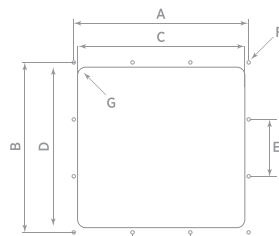

Drilling scheme	A	B	C	D	E	ØF	(r) G
RC 20.32	302	297	287	281	100	3,5	12,5

RC 20.32 - 320×320 | 520 m³/h

VENTILATION

- Axial fans supplied with grille and filter;
- High external profile;
- IP44 or IP54 protection degree;
- Quick and functional assembly of the fan on the electrical cabinet through elastic click hooks and gasket pre-installed on the product;
- Maximum operating temperature: +50°C;
- Possible installation with screws (provided);
- Slotted external grilles to allow drainage of condensation;
- Electrical connection through terminal block;
- Ball bearing motor;
- Body made of ABS self-extinguishing material grey RAL 7035;
- Grilles in grey RAL 7032 and 7035, black RAL 9005;
- Easily removable grille to allow quick replacement of the filter;
- In accordance with European Standard EN 60529, EN 60335-2-80.

TECHNICAL DATA

Model intake	Code	IP Grade	Voltage (V)	Frequency (Hz)	Colour grille	Flow rate (m ³ /h) with filter	Flow rate (m ³ /h) without filter	Power (W)	Nom. Curr. (A)	Noisiness dB(A) _{3m}	Weight (Kg)
RC 20.32	0095732	IP44	220-240	50/60 Hz	GREY RAL 7032	450	520	35	0,15	55	2,6
RC 20.32	0095735	IP44	220-240	50/60 Hz	BLACK RAL 7035	450	520	35	0,15	55	2,6
RC 20.32	0095705	IP44	220-240	50/60 Hz	BLACK RAL 9005	450	520	35	0,15	55	2,6
RC 20.32	0096132	IP44	110-120	50/60 Hz	GREY RAL 7032	450	520	35	0,3	55	2,6
RC 20.32	0096135	IP44	110-120	50/60 Hz	BLACK RAL 7035	450	520	35	0,3	55	2,6
RC 20.32	0096105	IP44	110-120	50/60 Hz	BLACK RAL 9005	450	520	35	0,3	55	2,6
RC 20.32	0089632	IP54	220-240	50/60 Hz	GREY RAL 7032	400	520	35	0,15	55	2,6
RC 20.32	0089635	IP54	220-240	50/60 Hz	BLACK RAL 7035	400	520	35	0,15	55	2,6
RC 20.32	0089605	IP54	220-240	50/60 Hz	BLACK RAL 9005	400	520	35	0,15	55	2,6
RC 20.32	0089532	IP54	110-120	50/60 Hz	GREY RAL 7032	400	520	35	0,3	55	2,6
RC 20.32	0089535	IP54	110-120	50/60 Hz	BLACK RAL 7035	400	520	35	0,3	55	2,6
RC 20.32	0089505	IP54	110-120	50/60 Hz	BLACK RAL 9005	400	520	35	0,3	55	2,6

FLOW CHARTS

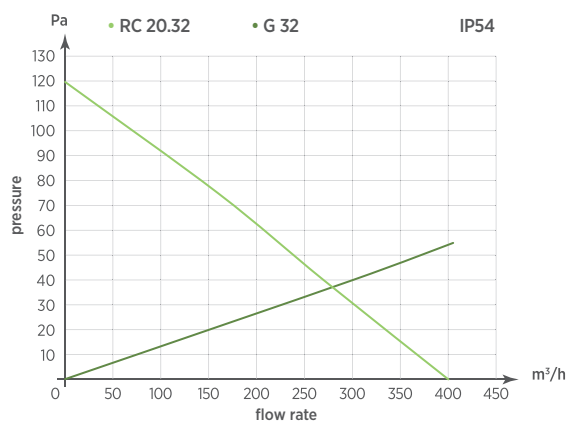
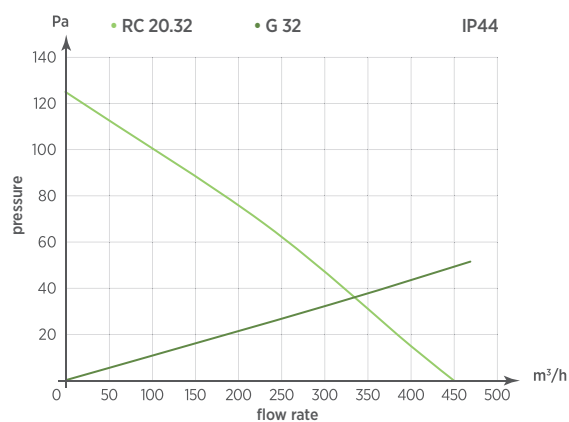

ACCESSORIES:

SEE PAGES 22 AND 44



Grilles



Thermostats



Hygrostat

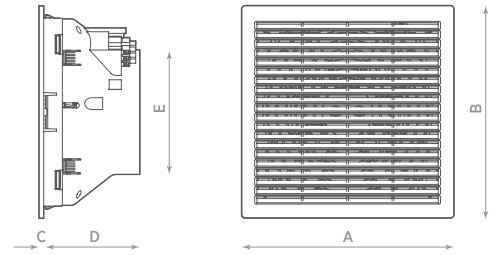

Model	A	B	C	D	ØE
RC 20.32 S	318,5	318,5	5,5	160	204

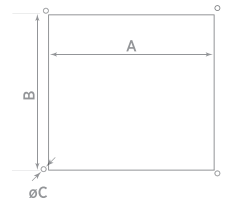

Drilling scheme	A	B	ØC
RC 20.32 S	291×291	302×302	4,5

RC 20.32 S - 320×320 | 520 m³/h

VENTILATION

- Axial fans supplied with grille and filter;
- Low external profile;
- IP44 or IP54 protection degree;
- Quick and functional assembly of the fan on the electrical cabinet through elastic click hooks and gasket pre-installed on the product;
- Maximum operating temperature: +50°C;
- Possible installation with screws (not provided);
- Slotted external grilles to allow drainage of condensation;
- Electrical connection through terminal block;
- Ball bearing motor;
- Body made of ABS self-extinguishing material grey RAL 7035;
- Grilles in grey RAL 7032 and 7035, black RAL 9005;
- Easily removable grille to allow quick replacement of the filter;
- In accordance with European Standard EN 60529, EN 60335-2-80.

TECHNICAL DATA

Model intake	Code	Model extraction	Code	IP Grade	Voltage (V)	Frequency (Hz)	Colour grille	Flow rate (m ³ /h) with filter	Flow rate (m ³ /h) without filter	Power (W)	Nom. Curr. (A)	Noisiness dB(A) _{5m}	Weight Kg
RC 20.32 S	0093432	-	-	IP44	220-240	50/60	GREY RAL 7032	450	520	35	0,15	55	2,6
RC 20.32 S	0093435	RC 20.32 S E	0103135	IP44	220-240	50/60	GREY RAL 7035	450	520	35	0,15	55	2,6
RC 20.32 S	0093405	-	-	IP44	220-240	50/60	BLACK RAL 9005	450	520	35	0,15	55	2,6
RC 20.32 S	0091132	-	-	IP44	110-120	50/60	GREY RAL 7032	450	520	35	0,3	55	2,6
RC 20.32 S	0091135	RC 20.32 S E	0103235	IP44	110-120	50/60	GREY RAL 7035	450	520	35	0,3	55	2,6
RC 20.32 S	0091105	-	-	IP44	110-120	50/60	BLACK RAL 9005	450	520	35	0,3	55	2,6
RC 20.32 S	0099732	-	-	IP54	220-240	50/60	GREY RAL 7032	400	520	35	0,15	55	2,6
RC 20.32 S	0099735	RC 20.32 S E	0103335	IP54	220-240	50/60	GREY RAL 7035	400	520	35	0,15	55	2,6
RC 20.32 S	0099705	-	-	IP54	220-240	50/60	BLACK RAL 9005	400	520	35	0,15	55	2,6
RC 20.32 S	0092232	-	-	IP54	110-120	50/60	GREY RAL 7032	400	520	35	0,3	55	2,6
RC 20.32 S	0092235	RC 20.32 S E	0103435	IP54	110-120	50/60	GREY RAL 7035	400	520	35	0,3	55	2,6
RC 20.32 S	0092205	-	-	IP54	110-120	50/60	BLACK RAL 9005	400	520	35	0,3	55	2,6

FLOW CHARTS

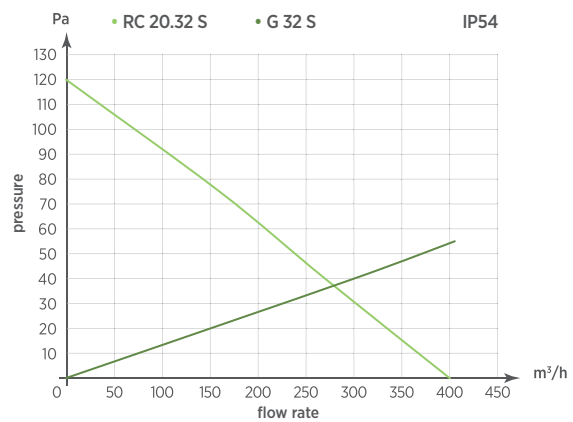
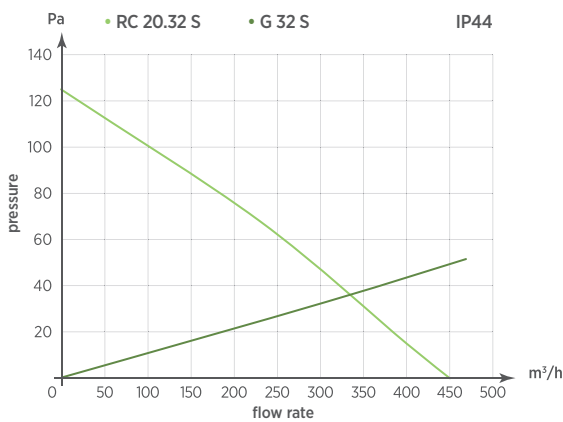

ACCESSORIES:
SEE PAGES 22 AND 44



Grilles



Thermostats



Hygostat

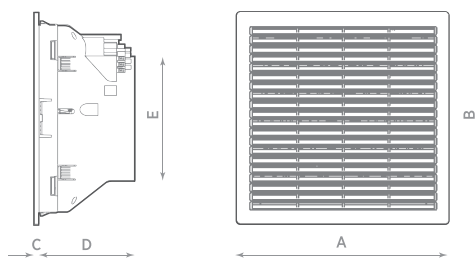

Model	A	B	C	D	ØE
RC 20.32 SP	318,5	318,5	5,5	160	204

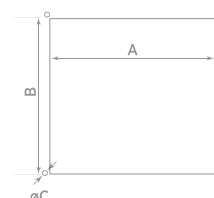

Drilling scheme	A	B	ØC
RC 20.32 SP	291×291	302×302	4,5

RC 20.32 SP - 320×320 | 800 m³/h

VENTILATION

- Axial fans supplied with grille and filter;
- Low external profile;
- IP44 or IP54 protection degree;
- Quick and functional assembly of the fan on the electrical cabinet through elastic click hooks and gasket pre-installed on the product;
- Maximum operating temperature: +50°C;
- Possible installation with screws (not provided);
- Slotted external grilles to allow drainage of condensation;
- Electrical connection through terminal block;
- Ball bearing motor;
- Body made of ABS self-extinguishing material grey RAL 7035;
- Grilles in grey RAL 7032 and 7035, black RAL 9005;
- Easily removable grille to allow quick replacement of the filter;
- In accordance with European Standard EN 60529, EN 60335-2-80.

TECHNICAL DATA

Model intake	Code	Model extraction	Code	IP Grade	Voltage (V)	Frequency (Hz)	Colour grille	Flow rate with filter (m ³ /h)	Flow rate without filter (m ³ /h)	Power (W)	Nom. Curr. (A)	Noisiness dB(A) _{2m}	Weight Kg
RC 20.32 SP	0103935	RC 20.32 SP E	0104135	IP44	220-240	50/60	GREY RAL 7035	650	800	55	0,3	56	2,6
RC 20.32 SP	0104035	RC 20.32 SP E	0104235	IP44	110-120	50/60	GREY RAL 7035	650	800	55	0,6	56	2,6
RC 20.32 SP	0103535	RC 20.32 SP E	0103735	IP54	220-240	50/60	GREY RAL 7035	600	800	55	0,3	56	2,6
RC 20.32 SP	0103635	RC 20.32 SP E	0103835	IP54	110-120	50/60	GREY RAL 7035	600	800	55	0,6	56	2,6

FLOW CHARTS

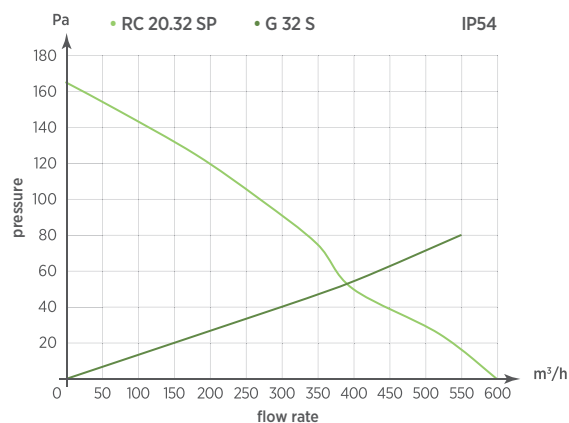
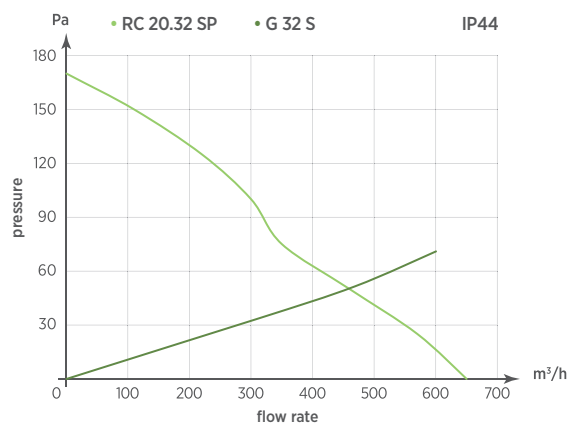

ACCESSORIES: SEE PAGES 22 AND 44



Grilles



Thermostats



Hygrostat



SYSTEMA VENTILATION

- Complete ventilation system;
- Kit composed of:
 1. complete fan with grille and filter;
 2. filter for air exhaust grille;
 3. grille for air exhaust
- IP43, IP44, IP54 or IP55 protection degrees;
- Body and grille made of ABS self-extinguishing material grey RAL 7035;
- In accordance with European Standard EN 60529, EN 60335-2-80.

TECHNICAL DATA

Model	Code	IP Grade	Voltage (V)	Frequency (Hz)	Colour grille	Flow rate (m³/h) with filter	Flow rate (m³/h) without filter	Power (W)	Nom. Curr. (A)	Noisiness dB(A) _{5m}	Weight Kg
SYSTEMA 10.13	0097500	IP44	220-240	50/60	GREY RAL 7035	24	59	16	0,1	38	0,6
SYSTEMA 10.13	0098300	IP44	110-120	50/60	GREY RAL 7035	24	59	16	0,2	38	0,6
SYSTEMA 12.13	0097600	IP44	220-240	50/60	GREY RAL 7035	42	67	17	0,11	38	0,6
SYSTEMA 12.13	0098400	IP44	110-120	50/60	GREY RAL 7035	42	67	17	0,22	38	0,6
SYSTEMA 12.13	0097400	IP54	220-240	50/60	GREY RAL 7035	20	67	17	0,11	38	0,6
SYSTEMA 12.13	0097300	IP54	110-120	50/60	GREY RAL 7035	20	67	17	0,22	38	0,6
SYSTEMA 14.25	0097700	IP43	220-240	50/60	GREY RAL 7035	115	250	30	0,22	40	1,2
SYSTEMA 14.25	0098500	IP43	110-120	50/60	GREY RAL 7035	115	250	30	0,44	40	1,2
SYSTEMA 14.25	0097800	IP44	220-240	50/60	GREY RAL 7035	110	250	30	0,22	40	1,2
SYSTEMA 14.25	0098600	IP44	110-120	50/60	GREY RAL 7035	110	250	30	0,44	40	1,2
SYSTEMA 14.25	0099200	IP54	220-240	50/60	GREY RAL 7035	85	250	30	0,22	40	1,2
SYSTEMA 14.25	0099300	IP54	110-120	50/60	GREY RAL 7035	85	250	30	0,44	40	1,2
SYSTEMA 14.32	0097900	IP44	220-240	50/60	GREY RAL 7035	130	270	30	0,22	39	1,6
SYSTEMA 14.32	0098700	IP44	110-120	50/60	GREY RAL 7035	130	270	30	0,44	39	1,6
SYSTEMA 20.32	0098100	IP44	220-240	50/60	GREY RAL 7035	360	520	35	0,15	55	2,6
SYSTEMA 20.32	0098900	IP44	110-120	50/60	GREY RAL 7035	360	520	35	0,3	55	2,6
SYSTEMA 20.32	0098200	IP55	220-240	50/60	GREY RAL 7035	136	520	35	0,15	55	2,6
SYSTEMA 20.32	0099000	IP55	110-120	50/60	GREY RAL 7035	136	520	35	0,3	55	2,6

OPERATION

The air, properly filtered and blown in the bottom of the cabinet, produces an internal overpressure which leads to the extraction through the grille placed on the top of the cabinet, following the natural ascending movement.

This process has concrete and significant benefits in terms of aging and operation quality of the products: the overpressure prevents entry of dust inside the panel, thus ensuring better operating conditions of electrical and electronic equipment inside.

Working under pressure, the fan blows air into the room at ambient temperature, granting benefits in terms of long lifetime and reliability of the appliance. This one is less mechanically strained compared to the extraction operation where air would be heated up by the previous cooling process of the internal circuits. Recommended to keep the fan and the exhaust grille as far as possible. A proper ventilation and regular maintenance of filters grant efficient cooling of the electrical equipment achieving better quality and longer lifetime.

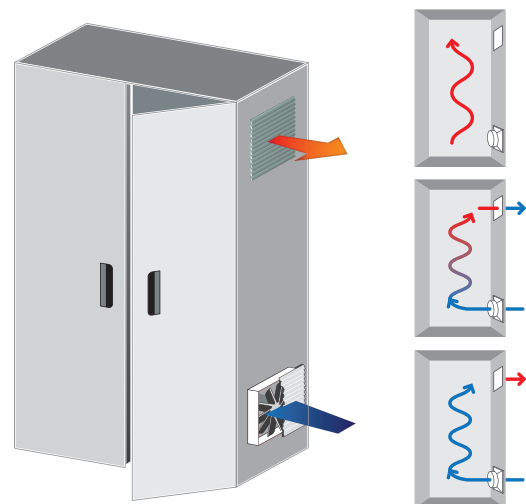

GRILLES AND FILTERS FOR RC SERIES

VENTILATION

High profile surface mounted exhaust grilles complete with IP54 or IP44 protection filter. High performance filters made of unbreakable synthetic fibre. Flame protection F1 level conforming to Standard DIN 53438.

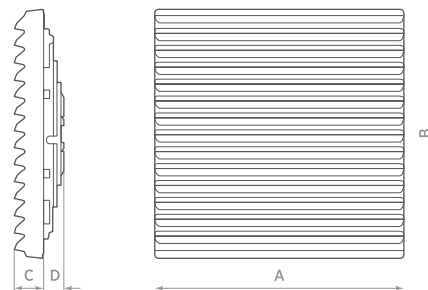
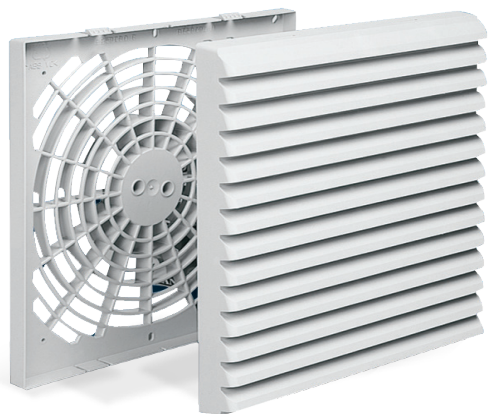

Model	A	B	C	D
G 13	130	140	24	22,5
G 25	256	256	30	21
G 32	323	322	36	30

TECHNICAL DATA

Description	IP Grade	Code RAL 7035	RAL 7032	RAL 9005	Suitable for series
grille G13	IP44	0096535	0096532	0096505	RC 12.13
grille G13	IP54	0092435	0092432	0092405	RC 12.13
grille G25	IP44	0095135	0095132	0095105	RC 14.25
grille G25	IP54	0092535	0092532	0092505	RC 14.25
grille G32	IP44	0096635	0096632	0096605	RC 14.32 - RC 20.32
grille G32	IP54	0089935	0089932	0089905	RC 14.32 - RC 20.32

Description	Quantity	Code IP43	IP44	IP54	IP55	Suitable for series
Filter F13	4	-	0096200	0096900	-	RC 12.13
Filter F25	4	0096700	0096800	0099100	-	RC 14.25
Filter F32	4	-	0096300	0094600	0096400	RC 14.32 - RC 20.32

HIGH PROFILE GRILLES AND FILTERS

VENTILATION

High profile surface mounted exhaust grilles complete with IP54 or IP44 protection filter. High performance filters made of unbreakable synthetic fibre. Flame protection F1 level conforming to Standard DIN 53438. Existing screw holes suitable for the mounting of RQ160 inside the electrical cabinet.

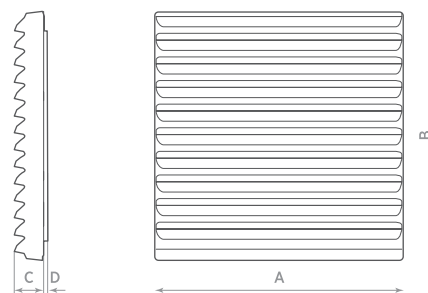

Model	A	B	C
G 15	140	130	24

Description	IP Grade	Code RAL 7035	RAL 7032	RAL 9005	Suitable for series
grille G15	IP54	0192735	0192732	-	RCQ 160.15 - RQ 160
grille G15	IP44	0189735	0189732	-	RCQ 160.15 - RQ 160

GRILLES AND FILTERS FOR RCS AND RCQ SERIES

VENTILATION

Low profile exhaust grilles complete with filter, IP44, IP54 or IP55 protection degree.

High performance filters made of unbreakable synthetic fibre. Flame protection level F1 conforming to Standard DIN 53438

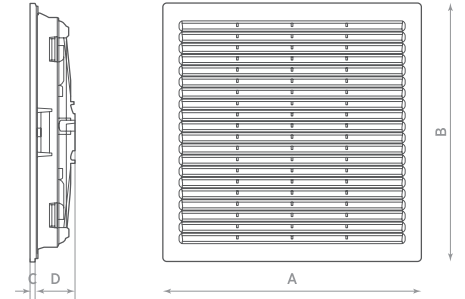
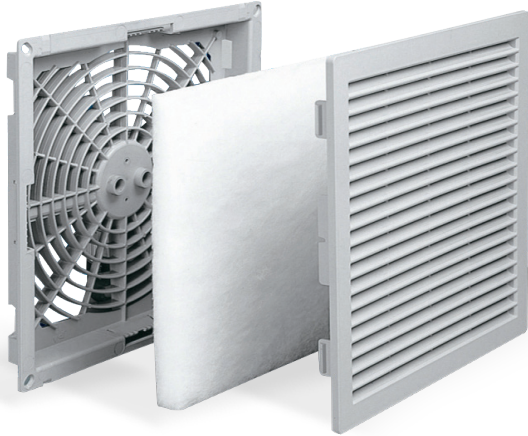

Model	A	B	C	D
G 11 S	110	110	4,5	19
G 15 S	148	148	4,5	26,5
G 25 S	250	250	5,5	37
G 32 S	318,5	318,5	5,5	46

TECHNICAL DATA

Description	IP Grade	Code			Suitable for series
		RAL 7035	RAL 7032	RAL 9005	
grille G11 S	IP44	0086135	0086132	0086105	RCQ 50.11
grille G11 S	IP54	0099935	0099932	0099905	RCQ 50.11
grille G15 S	IP44	0089735	0089732	0089705	RC 12.15 S - RCQ 160.15
grille G15 S	IP54	0092635	0092632	0092605	RC 12.15 S - RCQ 160.15
grille G15 S	IP55	0092655	-	-	RCQ 160.15
grille G25 S	IP44	0090835	0090832	0090805	RC 14.25 S - RCQ 160.25 - RCQ 370.25
grille G25 S	IP54	0092835	0092832	0092805	RC 14.25 S - RCQ 160.25 - RCQ 370.25
grille G32 S	IP44	0089835	0089832	0089805	RC 20.32 S - RC 20.32 SP
grille G32 S	IP54	0092735	0092732	0092705	RC 20.32 S - RC 20.32 SP

grille G11 S UL	IP54	0299935	-	-	RCQ 50.11 version UL
grille G15 S UL	IP54	0292635	-	-	RCQ 160.15 version UL
grille G15 S UL	IP55	0292655	-	-	RCQ 160.15 IP55 version UL
grille G25 S UL	IP54	0292835	-	-	RCQ 160.25 - RCQ 370.25 version UL

Description	Quantity	Code			Suitable for series
		IP44	IP54	IP55	
Filter F15	6	0088500	0088200	-	RC 12.15 S - RCQ 160.15
Filter F15	2	-	-	0088255	RCQ 160.15
Filter F25	6	0088700	0088400	-	RC 14.25 S - RCQ 160.25 - RCQ 370.25
Filter F32	6	0088600	0088300	-	RC 20.32 S

Filter F11 UL	6	-	0288520	-	RCQ 50.11 version UL
Filter F15 UL	6	-	0288200	0288255	RCQ 160.15 version UL
Filter F25 UL	6	-	0288400	-	RCQ 160.15 - RCQ 160.25 version UL

EXTRA SLIM AXIAL FANS

RQ 50 - RQ 60 - RQ 160 - RQ 370 - RQ 850

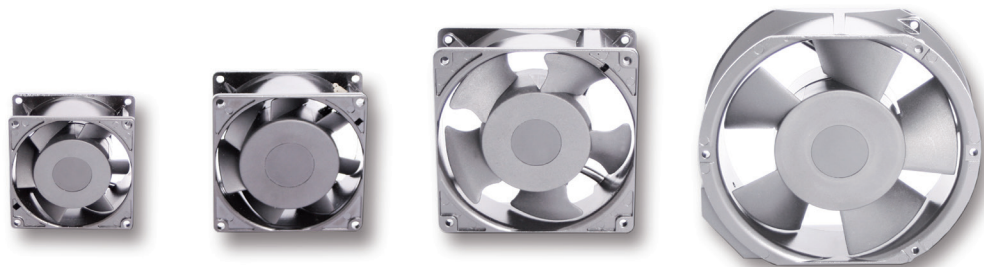

- Specifically designed to reduce temperature inside cabinets and electronic equipment;
- DC and AC axial fans;
- Ball bearing motor;
- Specifically designed for fitting in electrical and electronic equipment cabinets;
- Body made of nylon for DC Models, die-cast aluminium for AC Models;
- Impeller made of nylon reinforced with fiberglass except RQ 850 model;
- Maximum operating temperature: +70°C (except RQ 850 model +60°C)

DIMENSIONS

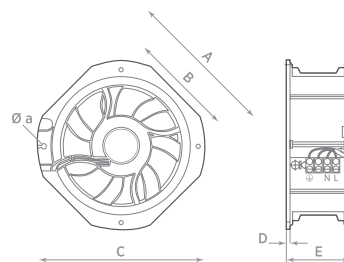
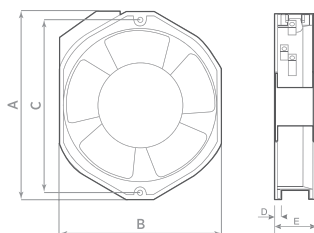
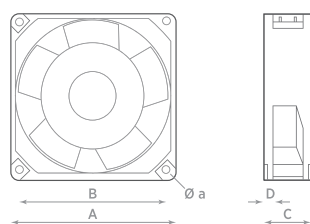

Model	Ø hole	A	B	C	D	Ø a	Kg
RQ 50 AC	78	80	71,4	38	3,5	4,3	0,3
RQ 50 DC	78	80	71,5	25	4	4,3	0,1
RQ 60 AC	90	92	82,5	38	3,5	4,3	0,45
RQ 160 AC	117	119	105	38	4	4,3	0,6
RQ 160 DC	117	119	105	38	5	4,3	0,22

Model	A	B	C	D	E	Ø hole	Ø a	Kg
RQ 370 AC	172	150	162	6	51	148	4,5	0,9
RQ 370 DC	172	150	162	6	51	149	4,2	0,8

Model	A	B	C	D	E	Ø hole	Ø a	Kg
RQ 850 AC	225	170	260	7	80	215	4,5	1,9

TECHNICAL DATA

Description	Code	Voltage (V)	Frequency (Hz)	max Flow rate (m³/h)	Absorbed Power (W)	Nom. curr. (A)	Rev. per min. (RPM)	Noisiness dB(A) _{1m}	Weight (Kg)
RQ 50	0058500	12	-	55	2	0,15	2500	22	0,1
RQ 50	0058600	24	-	55	2	0,08	2500	22	0,1
RQ 50	0040400	110-120	50/60	45	10	0,14	2400	27	0,3
RQ 50	0040100	220-240	50/60	45	10	0,07	2400	27	0,3
RQ 60	0058350	110-120	50/60	75	14	0,18	2800	32	0,45
RQ 60	0058300	220-240	50/60	75	14	0,09	2800	32	0,45
RQ 160	0058700	12	-	160	4	0,30	2200	31	0,22
RQ 160	0058800	24	-	160	4	0,15	2200	31	0,22
RQ 160	0040310	12	50/60	145	15	2	2600	38	0,51
RQ 160	0040300	24	50/60	145	15	1	2600	38	0,51
RQ 160	0040350	48	50/60	145	15	0,5	2600	38	0,51
RQ 160	0040500	110-120	50/60	145	20	0,22	2500	37	0,6
RQ 160	0040200	220-240	50/60	145	20	0,12	2500	37	0,6
RQ 370	0058940	12	-	300	11	0,86	2600	46	0,8
RQ 370	0058950	24	-	300	11	0,43	2600	46	0,8
RQ 370	0058960	48	-	300	13	0,28	2600	46	0,8
RQ 370	0058900	110-120	50/60	345	25	0,30	2700	45	0,9
RQ 370	0058400	220-240	50/60	345	25	0,15	2700	45	0,9
RQ 850	0058250	110-120	50/60	840	46	0,4	2400	52	2,0
RQ 850	0058200	220-240	50/60	840	44	0,2	2400	52	2,0

ACCESSORIES:



Protection grilles

Description	Code	Suitable for series
protection grille	0010800	RQ 50
protection grille	0064330	RQ 60
protection grille	0010900	RQ 160
protection grille	0064200	RQ 370
protection grille	0058260	RQ 850

grille + filter

Description	Code	Suitable for series
grille + filter	0064310	RQ 50
grille + filter	0064320	RQ 60
grille + filter	0064300	RQ 160

Cable connector

Description	Code	Suitable for series
in line connector	0064400	RQ series (with terminals)
45° connector	0064450	RQ series (with terminals)

T° AERATION



COOLED FORCED
AIR EXTRACTION

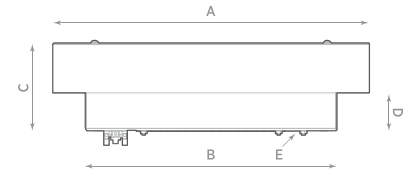

Model	A	B	C	D	E
TXQ 550	308×308	270×270	135	50	4-M6

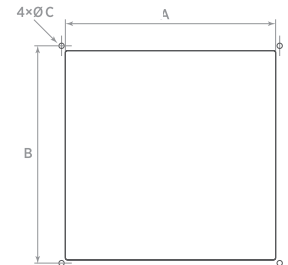

Drilling scheme	A	B	Ø C
TXQ 550	212	230	6,5

TXQ 550

AERATION

- Roof exhaust fan to extract air directly outside;
- Ball bearing motor;
- IP24 protection degree;
- IP44 side cabinet protection degree;
- Maximum air temperature 60°C;
- Quick and functional installation from inside the cabinet
- Supply cable (0,75 mt) included;
- Energy saving and reduced noise;
- Painted steel body complete with plastic cover, Grey colour RAL 7035;
- Safety protection grille;
- Ball bearing motor impeller self-cleaning backward curved blades;
- Adjustable speed through industrial controllers RGM2 or RGE (optional);
- Necessary to provide for installation an air intake grille in the lower part of the control cabinet;
- In accordance with Standard EN 60335-2-80.

TECHNICAL DATA

Model	Code	Voltage (V)	Frequency (Hz)	Flow rate (m³/h)	Power (W)	Nom. Curr. (A)	IP Grade		Noisiness dB(A) _{1m}	Weight (Kg)
							roof fan	side cabinet		
TXQ 550	0075800	230	50/60	450/500	80	0,35	IP 24	IP 44	54	3,5

FLOW CHARTS

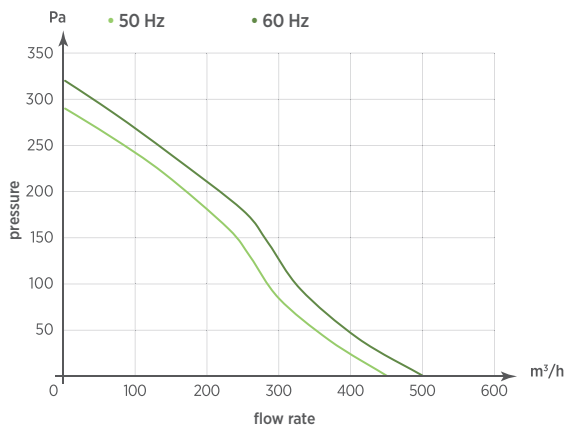

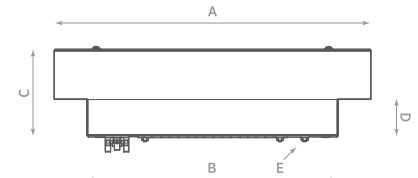

Model	A	B	C	D	E
TXQ M 550	365×365	290×290	105	45	4-M4
TXQ M 550 CA	365×365	290×290	105	45	4-M4

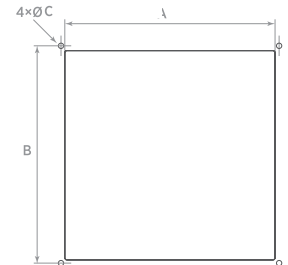

Drilling scheme	A	B	ØC
TXQ M 550	250	260	4,5

TXQ M 550

AERATION

- Roof exhaust fan to extract air directly outside;
- IP24 protection degree;
- IP44 side cabinet protection degree;
- Maximum air temperature 60°C;
- Quick and functional installation thanks to the electrical connection and mounting from the inside of the control cabinet;
- Energy saving and reduced noise;
- Painted steel body grey RAL 7035;
- Safety protection grille;
- Ball bearing motor impeller self-cleaning backward curved blades;
- Adjustable speed through industrial controllers RGM2 or RGE (optional);
- Necessary to provide for installation an air intake grille in the lower part of the control cabinet;
- In accordance with Standard EN 60335-2-80.

TECHNICAL DATA

Model	Code	Voltage (V)	Frequency (Hz)	Flow rate (m³/h)	Power (W)	Nom. Curr. (A)	IP Grade		Noisiness dB(A) _{1m}	Weight (Kg)
							roof fan	side cabinet		
TXQ M 550	0075810	230	50/60	510/570	60	0,26	IP 24	IP 44	52	5,8
TXQ M 550 CA	0075850	(Ventilation hood without motor)		-	-	-	IP 24	IP 44	-	3,2

(*) 110 V version available on request

FLOW CHARTS

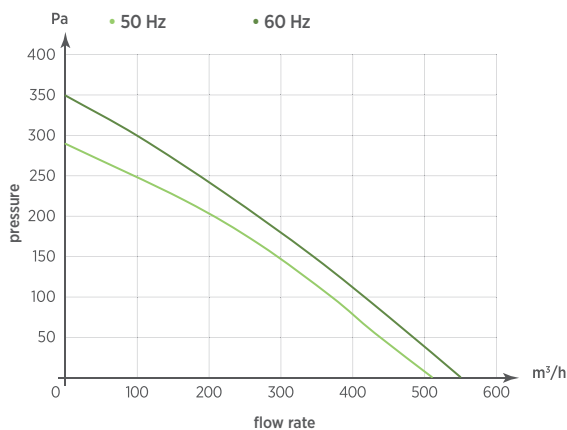

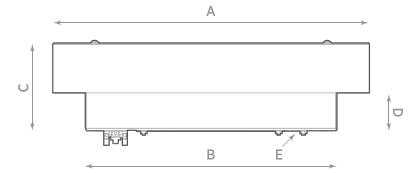

Model	A	B	C	D	E
TXQ M 860	365×365	290×290	105	45	4-M4
TXQ M 860 CA	365×365	290×290	105	45	4-M4

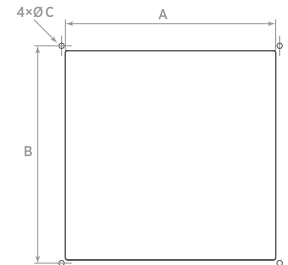

Drilling scheme	A	B	ØC
TXQ M 860	250	260	4,5

TXQ M 860

AERATION

- Roof exhaust fan to extract air directly outside;
- IP24 protection degree;
- IP44 side cabinet protection degree;
- Maximum air temperature 60°C;
- Quick and functional installation thanks to the electrical connection and mounting from the inside of the control cabinet;
- Energy saving and reduced noise;
- Painted steel body grey RAL 7035;
- Safety protection grille;
- Ball bearing motor impeller self-cleaning backward curved blades;
- Adjustable speed through industrial controllers RGM2 or RGE (optional);
- Necessary to provide for installation an air intake grille in the lower part of the control cabinet;
- In accordance with Standard EN 60335-2-80.

TECHNICAL DATA

Model	Code	Voltage (V)	Frequency (Hz)	Flow rate (m³/h)	Power (W)	Nom. Curr. (A)	IP Grade roof fan	side cabinet	Noisiness dB(A) _{3m}	Weight (Kg)
TXQ M 860	0075820	230	50/60	800/860	70	0,35	IP24	IP44	53	6,2
TXQ M 860 CA	0075850	(Ventilation hood without motor)		-	-	-	IP24	IP44	-	3,2

FLOW CHARTS

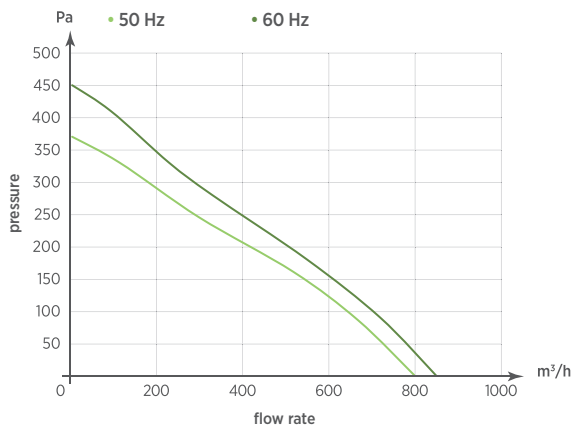

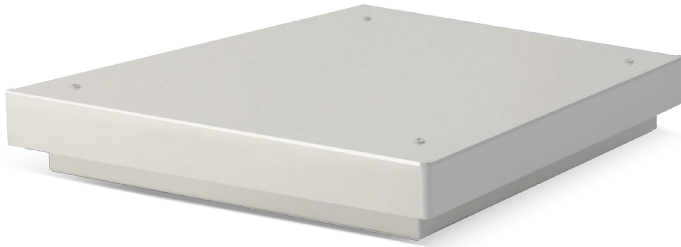

TXQ M 1500

AERATION

- Roof exhaust fan to extract air directly outside;
- IP24 protection degree;
- IP44 side cabinet protection degree;
- Maximum air temperature 60°C;
- Quick and functional installation thanks to the electrical connection and mounting from the inside of the control cabinet;
- Energy saving and reduced noise;

- Painted steel body grey RAL 7035;
- Safety protection grille;
- Ball bearing motor impeller self-cleaning backward curved blades;
- Adjustable speed through industrial controllers RGM2 or RGE (optional);
- Necessary to provide for installation an air intake grille in the lower part of the control cabinet;
- In accordance with Standard EN 60335-2-80.

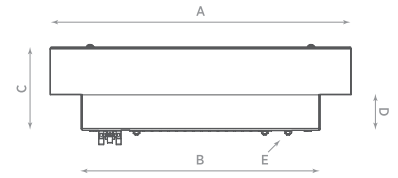

Model	A	B	C	D	E
TXQ M 1500	430x480	350x400	110	50	6-M4
TXQ M 1500 CA	430x480	350x400	110	50	6-M4

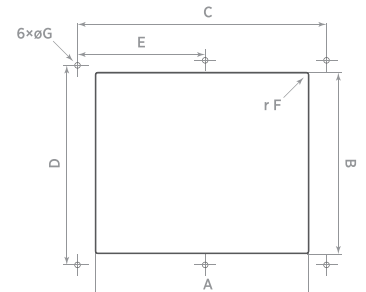

Drilling scheme	A	B	C	D	E	r	F	øG
TXQ M 1500	325	275	370	320	185	5	4,5	

TECHNICAL DATA

Model	Code	Voltage (V)	Frequency (Hz)	Flow rate (m³/h)	Power (W)	Nom. Curr. (A)	IP Grade		Noisiness dB(A) _{1m}	Weight (kg)
							roof fan	side cabinet		
TXQ M 1500	0075830	230	50/60	1470/1560	150	0,75	IP 24	IP 44	57	7,5
TXQ M 1500 CA	0075860	(Ventilation hood without motor)		-	-	-	IP 24	IP 44	-	4,5

(*) 110 V version available on request

FLOW CHARTS

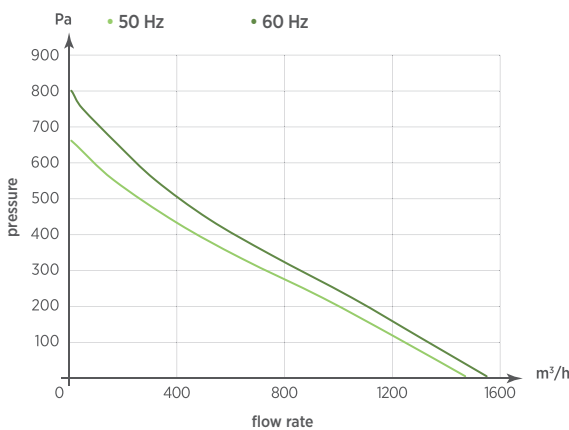

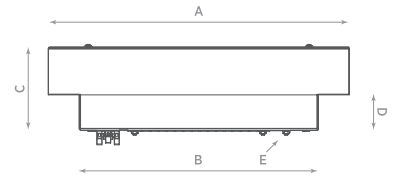

Model	A	B	C	D	E
TXQ M 2300	570×600	450×480	192	85	8-M4
TXQ M 2300 CA	570×600	450×480	192	85	8-M4

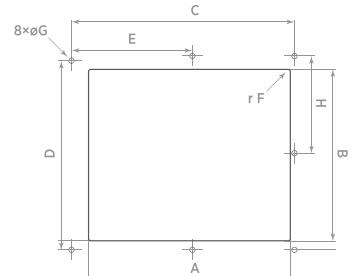

Drilling scheme	A	B	C	D	E	r	F	øG	H
TXQ M 2300	425	375	450	420	185	5	4,5	210	

TXQ M 2300

AERATION

- Roof exhaust fan to extract air directly outside;
- IP24 protection degree;
- IP44 side cabinet protection degree;
- Maximum air temperature 60°C;
- Quick and functional installation thanks to the electrical connection and mounting from the inside of the control cabinet;
- Energy saving and reduced noise;
- Painted steel body grey RAL 7035;
- Safety protection grille;
- Ball bearing motor impeller self-cleaning backward curved blades;
- Adjustable speed through industrial controllers RGM2 or RGE (optional);
- Necessary to provide for installation an air intake grille in the lower part of the control cabinet;
- In accordance with Standard EN 60335-2-80.

TECHNICAL DATA

Model	Code	Voltage (V)	Frequency (Hz)	Flow rate (m³/h)	Power (W)	Nom. Curr. (A)	IP Grade roof fan	side cabinet	Noisiness dB(A) _{3m}	Weight (Kg)
TXQ M 2300	0075840	230	50/60	2150/2310	200	0,80	IP24	IP44	58	10
TXQ M 2300 CA	0075870	(Ventilation hood without motor)		-	-	-	IP24	IP44	-	6,8

(*) 110 V version available on request

FLOW CHARTS

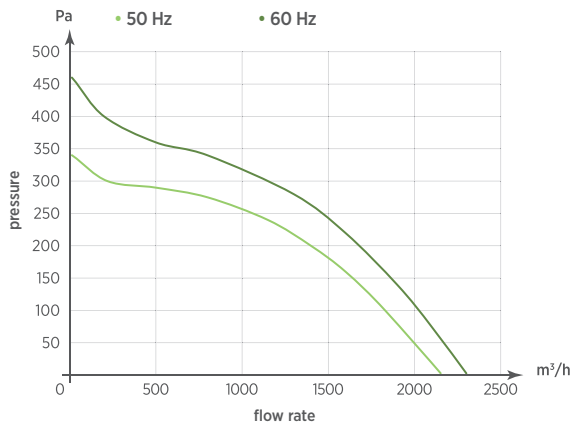

T° CONDITIONING



CONDITIONERS AND WATER/AIR EXCHANGERS



AC EM CONDITIONERS

CONDITIONING

- External, wall mount air conditioners;
- Thermal management independent from the external temperature;
- Meet the requirement to keep separate the environment inside control cabinet from the external environment;
- Hermetic type compressor, copper pipes/aluminium fins exchangers;
- R134a refrigerant charge;
- Easy maintenance;
- IP54 side cabinet protection degree;
- Internal and external fans with ball bearing motor;
- Painted steel cabinet grey RAL 7035;
- Easy installation;
- Suitable when a lower temperature inside cabinet and higher IP protection degree (IP54) is required;
- Standard digital electronic thermostat;
- Provided with sealing gasket, eyebolts for lifting, flexible pipe for condensation waste;
- Ambient temperature: $0 \div 55^{\circ}\text{C}$;
- Cabinet temperature: $20 \div 50^{\circ}\text{C}$.

TECHNICAL DATA

Model	Code	Voltage (V)	Frequency (Hz)	Total cooling capacity (W)		Power (W)	Nom. Curr. (A)	Start current (A)	Ventilator flow rate inside (m ³ /h)	IP Grade side cabinet	Noisiness dB(A) _{3m}	Weight (Kg)
				L35L35 - DIN 3168/EN814	L35L50 - DIN 3168/EN814							
AC EM 040	0088000	230	50/60	400	290	270	1,5	6	180	IP54	58	26
AC EM 065	0088010	230	50/60	640	470	305	1,65	7	280	IP54	60	25
AC EM 085	0088020	230	50/60	850	640	410	2,2	8,5	280	IP54	65	26
AC EM 110	0088030	230	50/60	1080	830	520	3,1	10	570	IP54	62	40
AC EM 150	0088050	230	50/60	1500	1150	740	4,2	19,7	570	IP54	62	40
AC EM 200	0088040	230	50/60	2000	1560	1090	4,9	21,8	860	IP54	60	43

Three phase Models, with total cooling capacity L35L35 DIN3168/EN814 from 2300 - 4000 - 5000 - 10000 W, available on request.

INSTALLATIONS

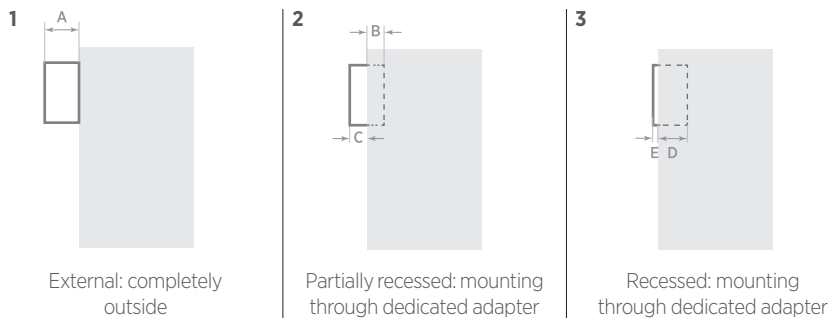

Model AC EM	A	B	C	D	E
040	216	100	116	190	26
065/085	220	110	110	180	40
110/150/200	249	100	151	225	26

ACCESSORIES

Description	Model	Code	Suitable for products
Adapter for wall air conditioner recessing	ARACEMS	0088101	AC EM 040
Adapter for wall air conditioner recessing	ARACEMM	0088102	AC EM 065 - 085
Adapter for wall air conditioner recessing	ARACEML	0088103	AC EM 110 - 150 - 200
Adapter for wall air conditioner partially recessing	APRACEMS	0088104	AC EM 040
Adapter for wall air conditioner partially recessing	APRACEMM	0088105	AC EM 065 - 085
Adapter for wall air conditioner partially recessing	APRACEML	0088106	AC EM 110 - 150 - 200
Filter holder with poliuretano filter for wall air conditioner	FHACEMS	0088107	AC EM 040 - 065 - 085
Filter holder with poliuretano filter for wall air conditioner	FHACEML	0088108	AC EM 110 - 150 - 200
Dust poliuretano filter for ambient air intake grille	FPACEMS	0088109	AC EM 040 - 065 - 085
Dust poliuretano filter for ambient air intake grille	FPACEML	0088111	AC EM 110 - 150 - 200
Filter oil resistant for ambient air intake grille	FOACEMS	0088112	AC EM 040 - 065 - 085
Filter oil resistant for ambient air intake grille	FOACEML	0088113	AC EM 110 - 150 - 200

DIMENSIONS

AC EM 040

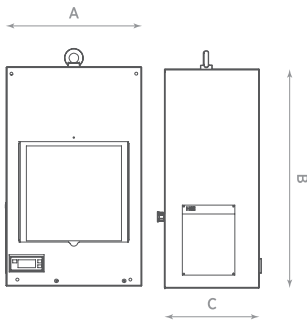

Model AC EM	A	B	C
040	310	500	216

AC EM 065/085

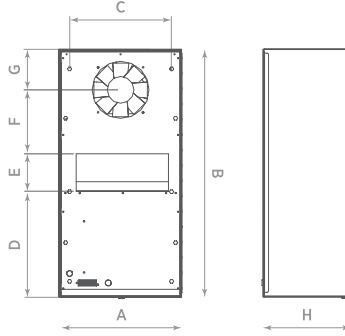

Model AC EM	A	B	C	D	E	F	G	H
065/085	313	630	260	269,5	95	162,5	103	222

AC EM 110/150/200

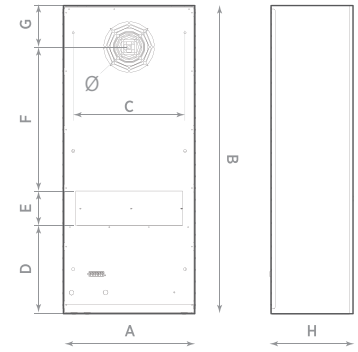

Model AC EM	A	B	C	D	E	F	G	H	Ø
110/150/200	403	940	340	267,2	105	438,5	128	250	155

DRILLING TEMPLATE

AC EM 040

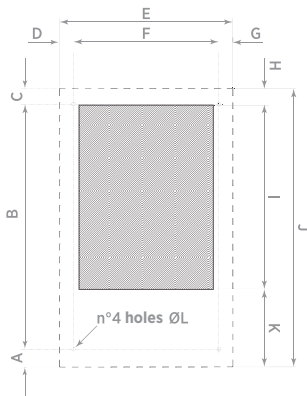

AC EM 065/085

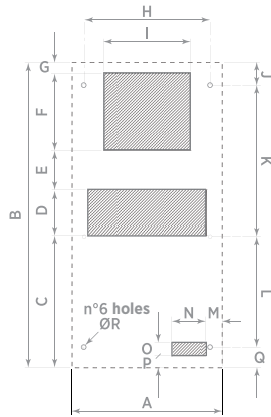

AC EM 110/150/200

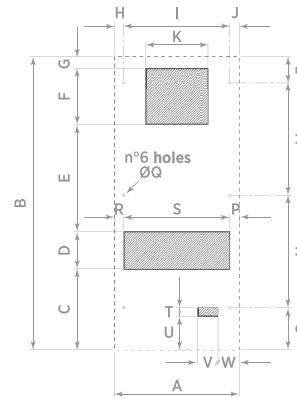

Model AC EM	A	B	C	D	E	F	G	H	I	J	K	L	M	N	O	P	Q	R	S	T	U	V	W
AC EM 040	32	440	28	25	310	260	25	30	330	500	140	7	-	-	-	-	-	-	-	-	-	-	-
AC EM 065/085	310	630	272,5	95	81	160	21,5	260	180	47,5	312	228	34	70	28	24,5	42,5	8	-	-	-	-	-
AC EM 110/150/200	400	940	260	120	342,5	180	37,5	30	340	30	200	84,5	360	360	135,5	30	7	30	340	28	107	65	68

COOLING CAPACITY CURVES

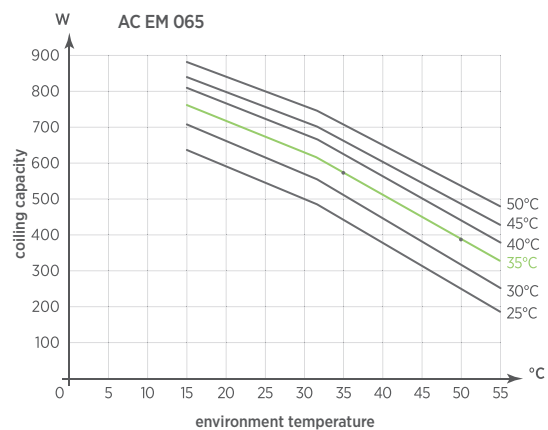
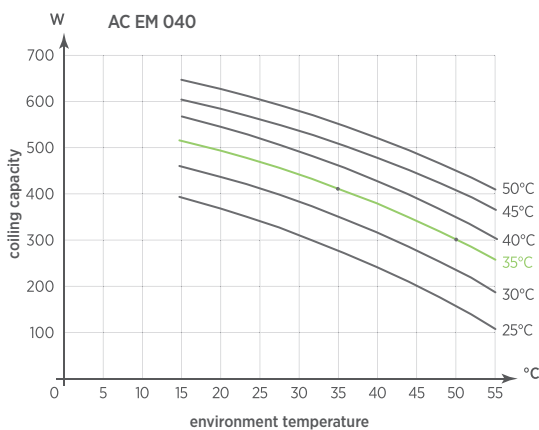

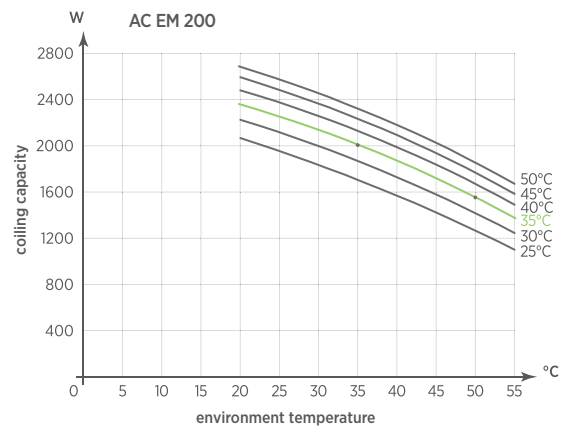
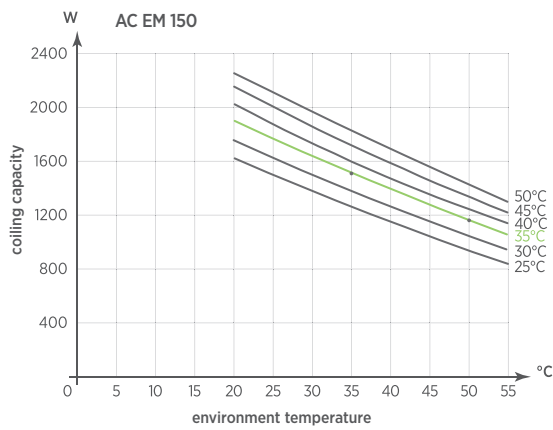
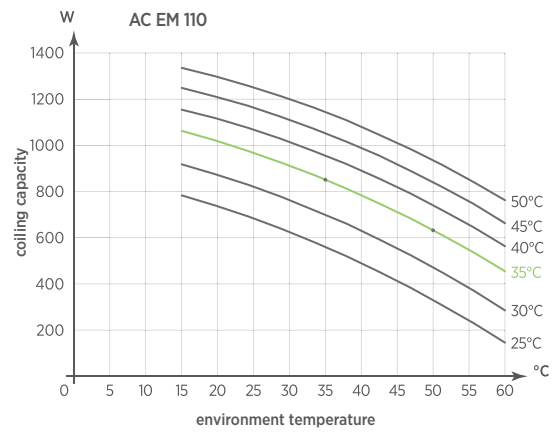
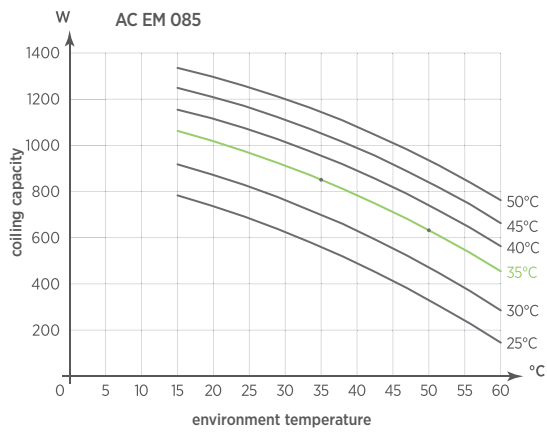

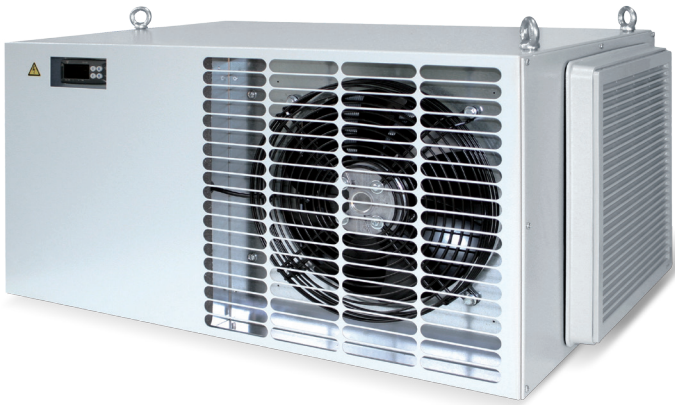

AC RM CONDITIONERS

CONDITIONING

- External, roof mount air conditioners;
- Thermal management independent from the external temperature;
- Meet the requirement to keep separate the environment inside control cabinet from the external environment;
- Hermetic type compressor, copper pipes/aluminium fins exchangers;
- R134a refrigerant charge;
- Easy maintenance;
- IP54 side cabinet protection degree;
- Internal and external fans with ball bearing motor;
- Painted steel cabinet grey RAL 7035;
- Easy installation;
- Suitable when a lower temperature inside cabinet and higher IP protection degree (IP54) is required;
- Standard digital electronic thermostat, provided with sealing gasket, eyebolts for lifting, flexible pipe for condensation waste;
- Ambient temperature: 0 ÷ 55°C
- Cabinet temperature: 20 ÷ 50°C

TECHNICAL DATA

Model	Code	Voltage (V)	Frequency (Hz)	Total cooling capacity		Power (W)	Nom. Curr. (A)	Start current (A)	Flow rate internal fan (m³/h)	IP Grade side cabinet	Noisiness dB(A) _{3m}	Weight (Kg)
				L35L35 - DIN 3168/EN814	L35L50 - DIN 3168/EN814							
AC RM 060	0085905	230	50/60	600	420	370	2,2	7	570	IP54	60	38
AC RM 080	0085910	230	50/60	800	600	400	2,4	8,5	570	IP54	60	39
AC RM 110	0085915	230	50/60	1100	780	515	2,9	10	570	IP54	60	42
AC RM 150	0085920	230	50/60	1500	1240	750	4	20	860	IP54	65	45
AC RM 170	0085925	230	50/60	1700	1360	870	4,6	20	860	IP54	65	46
AC RM 210	0085930	230	50/60	2100	1560	1040	5	24	860	IP54	65	48

Three phase Models, with total cooling capacity L35L35 DIN3168/EN814 from 1700 -2300 - 2800 W, available on request.

ACCESSORIES

Description	Model	Code	Suitable for products
Dust poliuretano filter for ambient air intake grille	FPACRMS	0088114	AC RM 060-080-110
Dust poliuretano filter for ambient air intake grille	FPACRML	0088115	AC RM 150-170-210
Filter oil resistant for ambient air intake grille	FOACRMS	0088116	AC RM 060-080-110
Filter oil resistant for ambient air intake grille	FOACRML	0088117	AC RM 150-170-210

DIMENSIONS

AC RM 060/080/110

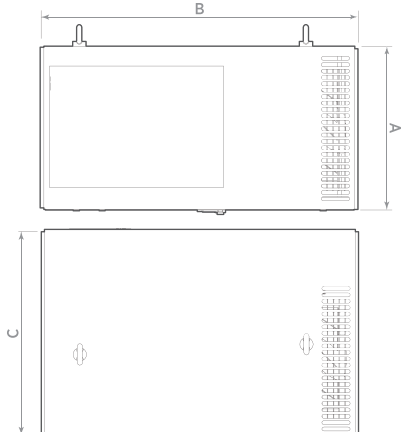

Model AC RM	A	B	C
060/080/110	321	617	400

AC RM 150/170/210

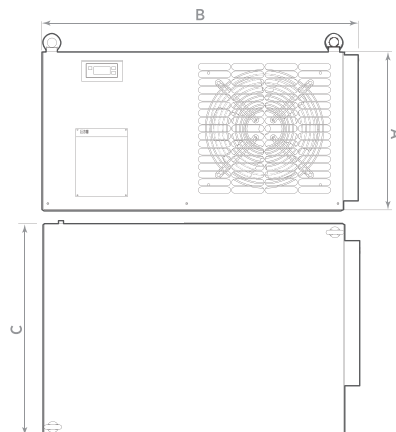

Model AC RM	A	B	C
150/170/210	370	700	495

DRILLING TEMPLATE

AC RM 060/080/110

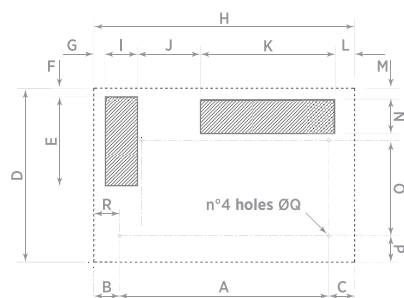

AC RM 150/170/210

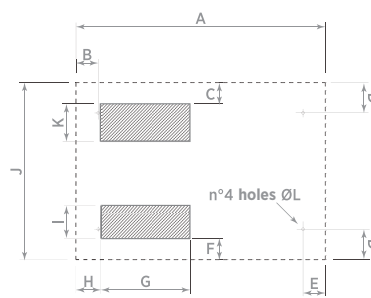

Model	A	B	C	D	E	F	G	H	I	J	K	L	M	N	O	P	Q	R
AC RM 060/080/110	480	60	60	400	205	20	25	600	75	145	310	45	25	80	220	60	7	50
AC RM 150/170/210	700	62,5	60	85	62,5	60	250	70	90	495	105	8	-	-	-	-	-	-

COOLING CAPACITY CURVES

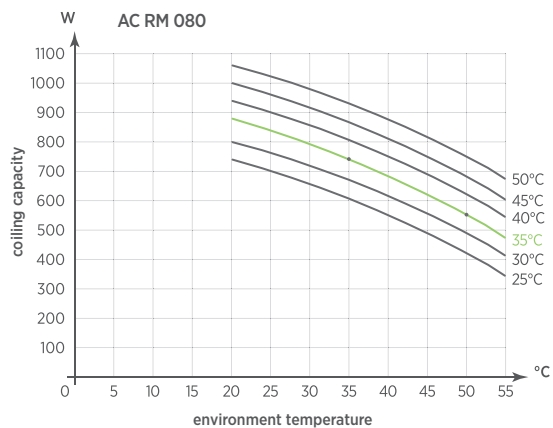
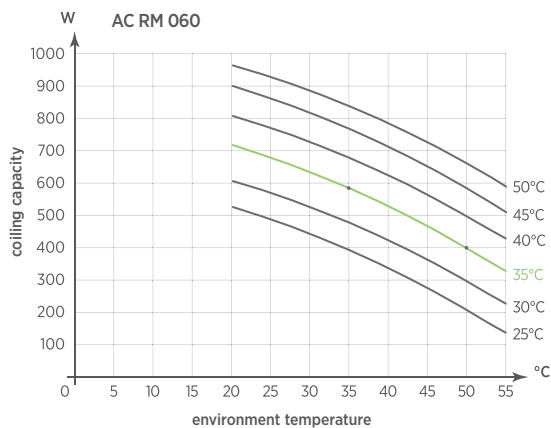

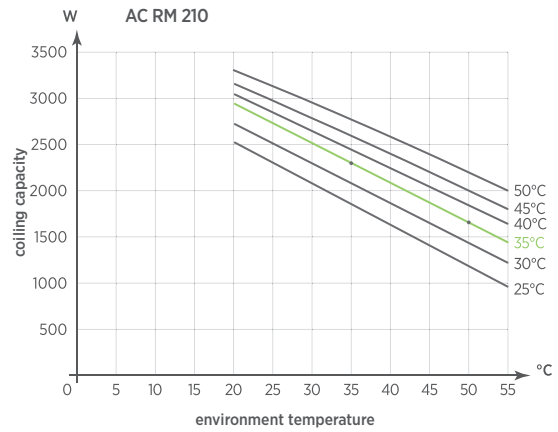
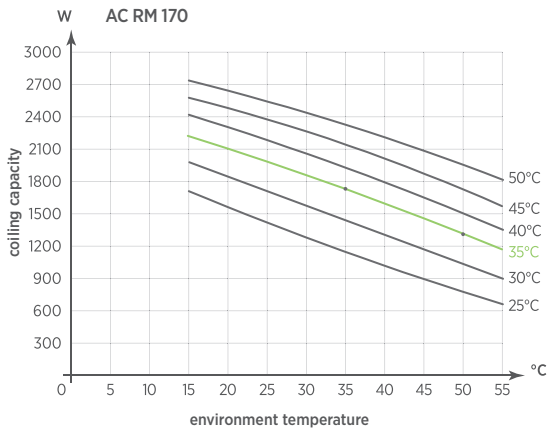
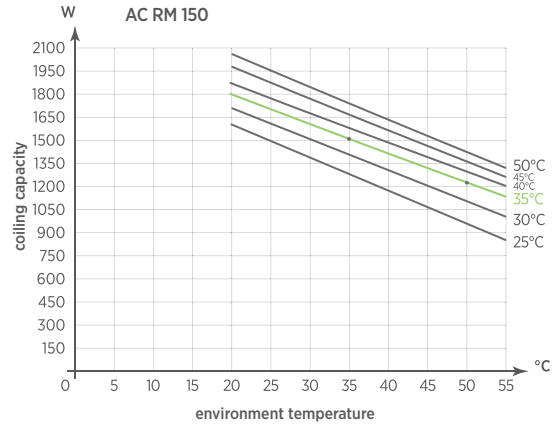
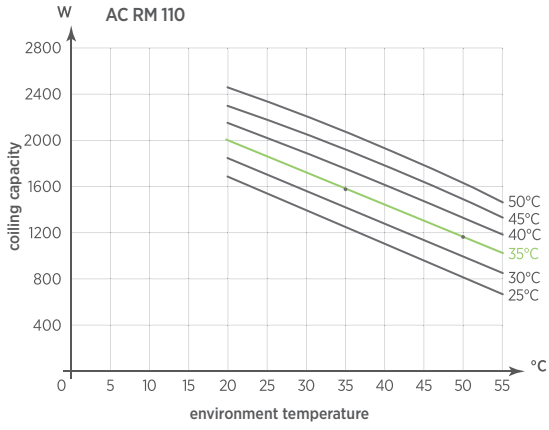

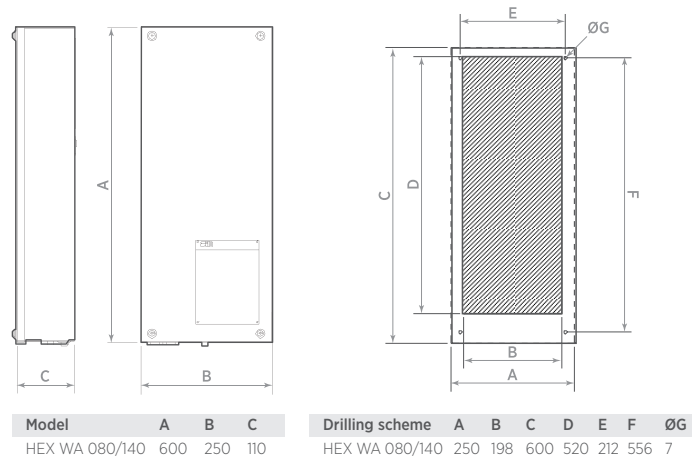

HEX WA EXCHANGER

WATER/AIR HEAT EXCHANGERS

- External, wall mount water to air heat exchangers;
- Suitable to maintain an internal cabinet constant temperature, taking advantage of the cold water availability;
- Maintenance free;
- IP65 side cabinet protection degree gasket properly installed;
- Internal fans with ball bearing motor;
- Painted steel cabinet grey RAL 7035
- Easy installation;

- Suitable for specific applications in difficult environments both for temperature and pollution;
- Suitable when a higher IP protection degree inside cabinet is required (water jets, conductive dusts);
- Cooling water connection 3/8 inches;
- Ambient temperature: 1 ÷ 70°C;
- Cabinet temperature: 1 ÷ 55°C.

TECHNICAL DATA

Model	Code	Voltage (V)	Frequency (Hz)	Total cooling capacity L35W10 (*)	Water flow rate (l/h)	Water pressure max (KPa)	Nom. power (W)	Nom. Curr. (A) interno (m³/h)	Ventilator flow rate	IP Grade (side cabinet)	Noisiness dB(A) _{1m}	Weight (Kg)
HEX WA 080	0085840	230	50/60	780	150	800	28	0,2	200	IP65 (**)	55	7
HEX WA 140	0085850	230	50/60	1350	200	800	58	0,26	300	IP65 (**)	62	8

Models, with total cooling capacity L35W10 DIN3168/EN814 from 2500 -4100 W, available on request. (*) DIN 3168/EN814 (***) with gasket properly installed

COOLING CAPACITY CURVES

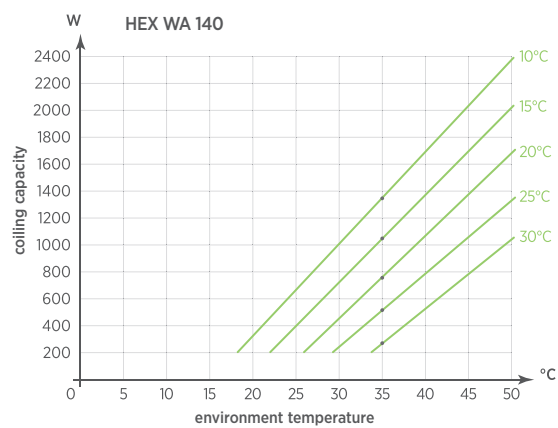
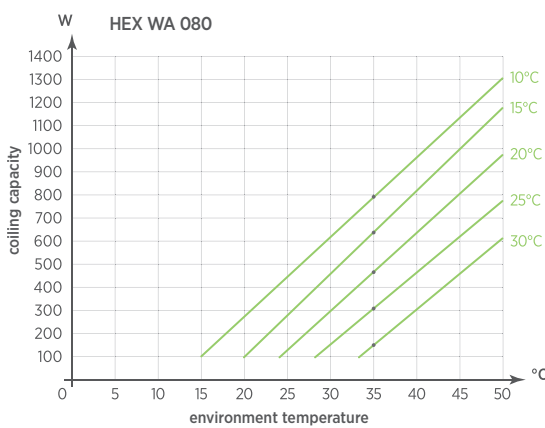

IN EVIDENCE

The connections of the hydraulic circuit, misaligned, allow the regular coupling of the connection pipes whatever is their orientation.



T° ANTI-CONDENSATION



TO PREVENT CONDENSATION
INSIDE THE ELECTRICAL CABINET

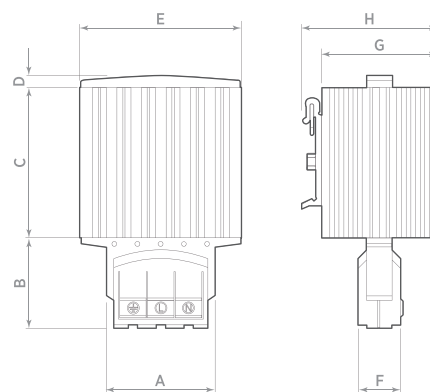

Model	A	B	C	D	E	F	G	H
HE 30	47	39	65	5	70	20	50	60
HE 60	47	39	65	5	70	20	50	60
HE 100	47	39	145	5	70	20	50	60
HE 150	47	39	195	5	70	20	50	60

HE

ANTI-CONDENSATION HEATERS

- Heaters designed to prevent condensation and to ensure a minimum operating temperature in the control cabinets;
- They are a valid support for the correct functioning of the other electric components in the control cabinet;
- Made of extruded aluminium anodised with a PTC resistor inside;
- Energy saving;
- Cage clamp connectors for quick and easy wiring: with stranded wire 0,5 -1,5 mm²; with rigid wire 0,5 - 2,5 mm²;
- Clip for 35 mm DIN rail;
- Storage temperature range: -40 ÷ 80°C;
- Operating temperature range: -40 ÷ 70°C;
- Vertical mounting position (with bottom connection terminals).

TECHNICAL DATA

Model	Code	Voltage (V AC/DC)	Power nom. (W)	Nom. Curr. (A)	Starting current (A)	IP Grade	Weight (Kg)
HE 30	0086000	110-250	30	0,25	1,5	IP20	0,3
HE 60	0086010	110-250	60	0,32	1,5	IP20	0,4
HE 100	0086020	110-250	100	0,58	2	IP20	0,5
HE 150	0086030	110-250	150	0,66	2,5	IP20	0,7

INSTALLATION EXAMPLE

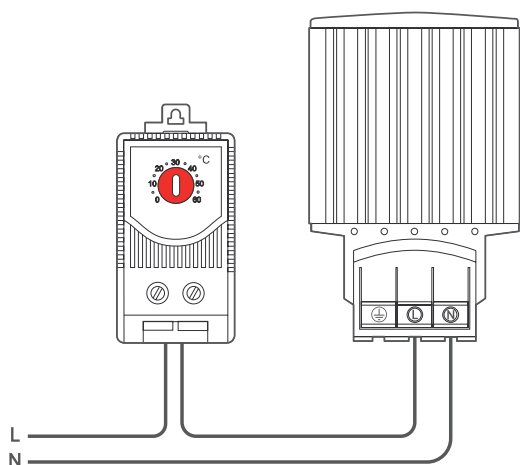

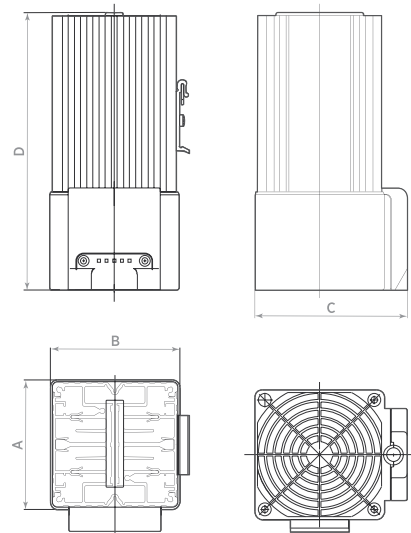

Model	A	B	C	D
HEV 250	85	85	100	182
HEV 400	85	85	100	222

HEV

ANTI-CONDENSATION VENTILATED HEATERS

- Heaters designed to prevent condensation and to ensure a minimum operating temperature in the control cabinets;
- They are a valid support for the correct functioning of the other electric components in the control cabinet;
- The integrated axial fan provides forced air circulation;
- Made of extruded aluminium anodised with a PTC resistor inside;
- Internal connection terminal 2,5 mm²
- Clip for 35mm DIN rail;
- Storage temperature range: -40 ÷ 80°C
- Operating temperature range: -40 ÷ 70°C;
- Vertical mounting position (with bottom connection terminals).

TECHNICAL DATA

Model	Code	Voltage (V)	Frequency (Hz)	Power nom. (W)	Nom. Curr. (A)	Starting current (A)	IP Grade	Weight (kg)
HEV 250	0086040	230	50/60	250	1,25	1,3	IP20	1,1
HEV 400	0086050	230	50/60	400	1,6	1,7	IP20	1,4

INSTALLATION EXAMPLE

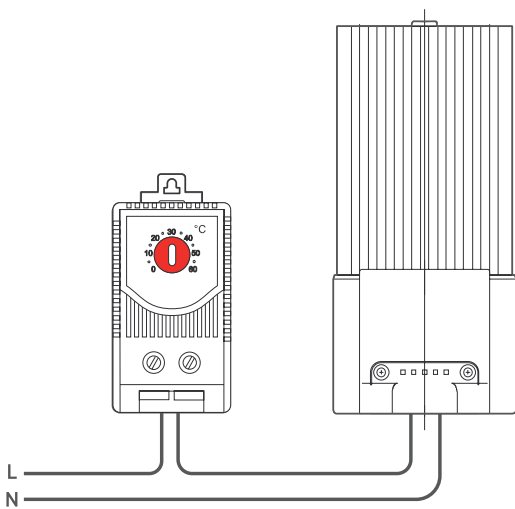

ACCESSORIES



THERMOSTAT, HYGROSTAT,
POCKET WALLET

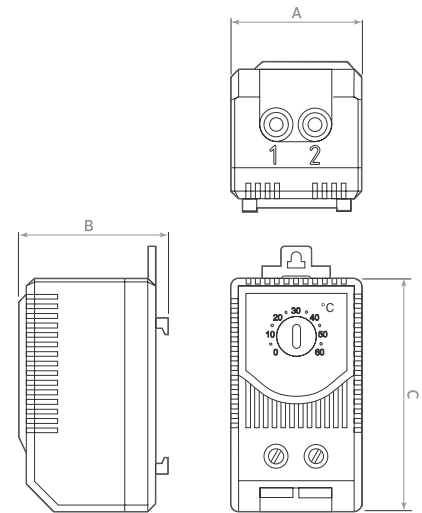

Model	A	B	C
TMS NO	33	43	60
TMS NC	33	43	60
TMS	30	78	78

TMS - TMS NC - TMS NO THERMOSTATS

- Thermostats used to control temperature inside the control cabinets;
- Suitable for controlling filter fans and heaters;
- Small size;
- Bi-metallic sensor element;
- Clip for 35mm DIN rail;
- Endurance > 100.000 cycles;
- Variable fitting position;

- Storage temperature range: $-45 \div 80^{\circ}\text{C}$;
- 2 poles terminal, rigid wire $2,5\text{ mm}^2$, stranded wire $1,5\text{ mm}^2$;
- TMS NO (blue regulation knob) normally open contact, for switching filter fans when the temperature limit has been exceeded;
- TMS NC (red regulation knob) normally closed contact for switching heaters when the detected temperature is lower than the preset one.

TECHNICAL DATA

Model	Code	Hysteresis (K)	Setting	AC Commut. (resistive load)	AC Commut. (inductive load)	DC commut. power (W)	Protection degree	Weight (Kg)
TMS NO	0097010	7 (tolerance + 4 K)	from 0°C a $+60^{\circ}\text{C}$	250 V, 10 A a 120 V, 15 A	250 V, 2 A a 120 V, 2 A	30	IP20	0,04
TMS NC	0097020	7 (tolerance + 4 K)	from 0°C a $+60^{\circ}\text{C}$	250 V, 10 A a 120 V, 15 A	250 V, 2 A a 120 V, 2 A	30	IP20	0,04
TMS	0097000	0,5	from $+20^{\circ}\text{C}$ a $+60^{\circ}\text{C}$	250 V, 10 A	250 V, 2 A	30	IP30	0,09

INSTALLATION EXAMPLE

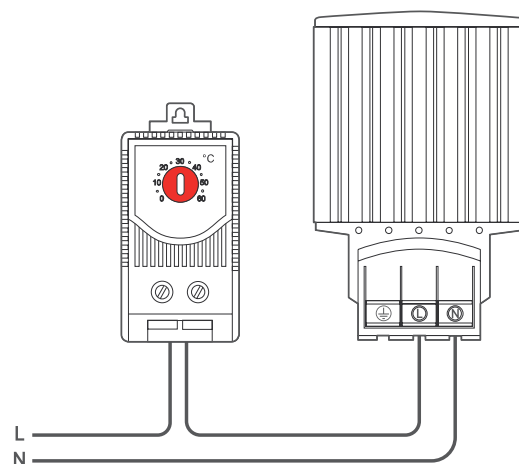
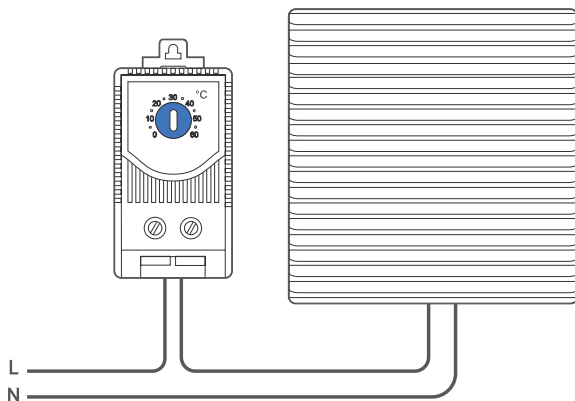

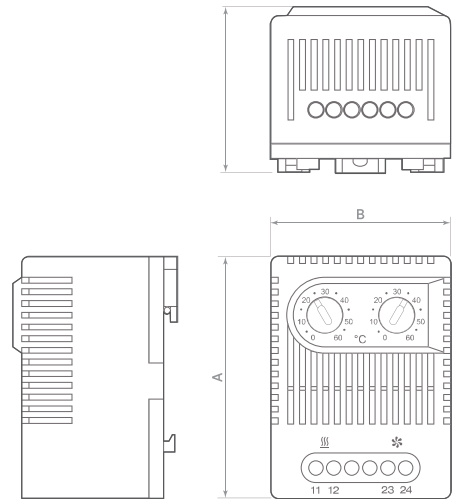

Model	A	B	C
TMS D	67	50	46

TMS D TMS DUAL THERMOSTAT

- TMS D dual thermostat, for controlling separately on/off switch of filter fans and heaters;
- Normally open contact, for switching filter fans when the temperature limit has been exceeded;
- Normally closed contact for switching heaters when the temperature limit goes down the preset one;
- Small size;
- Bi-metallic sensor element;
- Clip for 35mm DIN rail;
- Endurance > 100.000 cycles;
- Variable fitting position;
- Storage temperature range: $-45 \div 80^{\circ} \text{C}$;
- 4 poles terminal, rigid wire $2,5 \text{ mm}^2$, stranded wire $1,5 \text{ mm}^2$.

TECHNICAL DATA

Model	Code	Hysteresis (K)	Setting	AC Commut. (resistive load)	AC Commut. (inductive load)	DC commut. power (W)	IP grade	Weight (Kg)
TMS D	0097030	7 (tolerance + 4 K)	from 0°C to $+60^{\circ}\text{C}$	250 V, 10 A 120 V, 15 A	250 V, 2 A 120 V, 2 A	30	IP20	0,09

INSTALLATION EXAMPLE

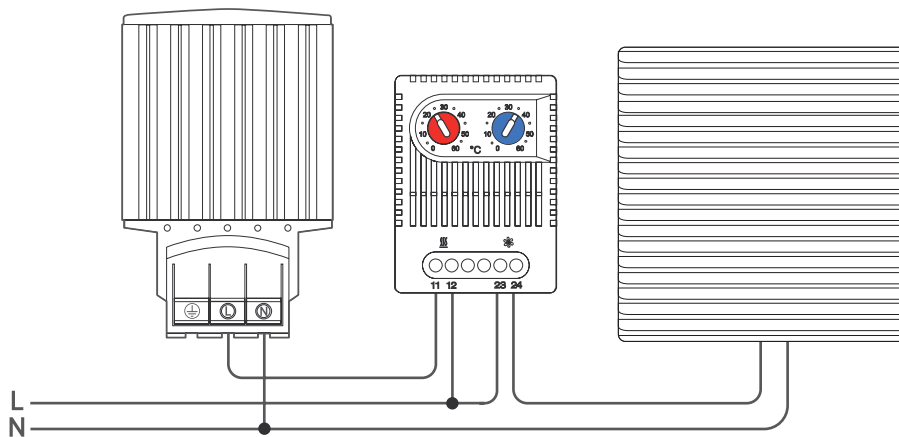

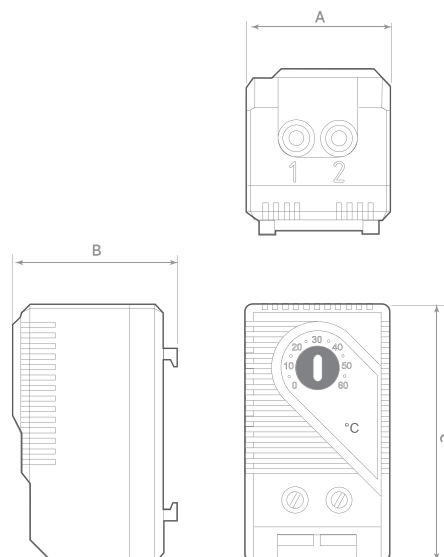

HYM

MECHANICAL HYGROSTAT

- Hygrostat for regulating humidity inside the control cabinets;
- Suitable for controlling filter fans, heaters when a preset humidity level is exceeded;
- Small size;
- Clip for 35mm DIN rail;

- Endurance > 100.000 cycles;
- Variable fitting position;
- Storage temperature range: -20 ÷ 80°C;
- 3 poles terminal, rigid wire 2,5 mm², stranded wire 1,5 mm².

Model	A	B	C
HYM	33	43	60

TECHNICAL DATA

Model	Code	Hysteresis (RH)	Setting Range	Resistance contact	Min Comm. in AC/DC (A)	AC Commut. (resistive load)	AC Commut. (inductive load)	DC Commut. power (W)	IP grade	Weight (Kg)
HYM	0097040	4% (tolerance +3%)	from 35% to 95%	< 10 m ohm	20 V, 100 mA	250 V, 5A	250 V, 1A	20	IP20	0,06

INSTALLATION EXAMPLE

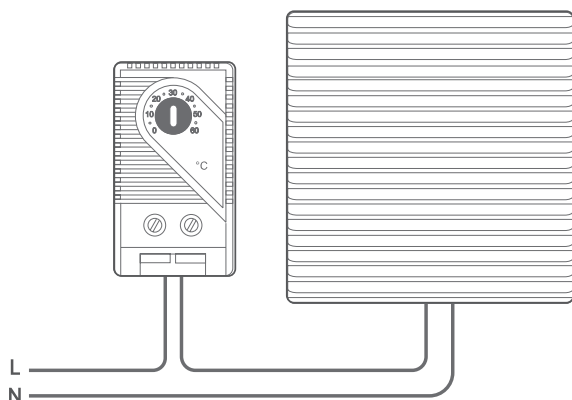

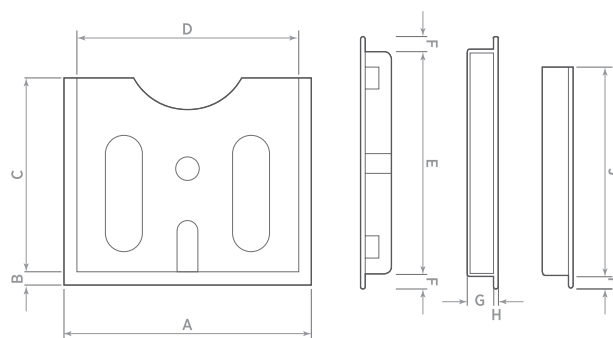
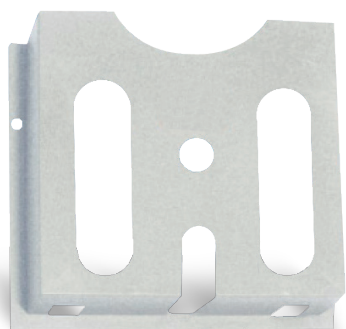

Model	A	B	C	D	E	F	G	H	I	J
PW	263	3,5	2201	235	235	13,5	30	2,5	13,5	220

PW

POCKET WALLET

Pocket wallet made of plastic material, A4 format. Specially designed to contain wiring diagrams of the control cabinet. Supplied with pre-mounted double-sided adhesive. Holes for optional screws fixing (screws not provided).

TECHNICAL DATA

Model	Code
PW	0097050

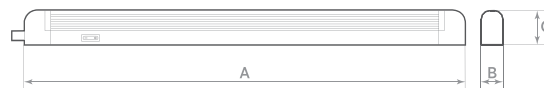

Model	A	B	C
FCL 6	280	22	42
FCL 8	350	22	42
FCL 13	570	22	42
FCL 21	915	22	42

FCL

FLUORESCENT LAMPS

- Fluorescent compact lamps for lighting of control cabinets;
- Casing lamp made of thermoplastic and diffuser in transparent striped polymethacrylate;
- ON/OFF switch;
- Equipped with fluorescent lamps type T5;
- IP20 protection degree;
- Operating temperature range: $+5 \div 45^{\circ}\text{C}$
- Fixing with click hooks with screws (provided);
- Possibility to connect multiple lamps through the connection cable provided (0,15 mt);
- Power cable 1,70 mt;
- Energy saving.

TECHNICAL DATA

Model	Code	Voltage (V)	Frequency (Hz)	Power nom. (W)	Lamp holder	Lamp	Colour Temperature(°K)	IP grade	Weight (Kg)
FCL 6	0097060	230	50	6	G5	T5	6500	IP20	0,09
FCL 8	0097070	230	50	8	G5	T5	6500	IP20	0,12
FCL 13	0097080	230	50	13	G5	T5	6500	IP20	0,2
FCL 21	0097090	230	50	21	G5	T5	6500	IP20	0,3

MOUNTING INSTRUCTIONS

(PROVIDED EQUIPMENT)

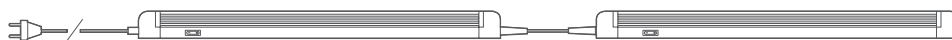

SELECTION CHART FOR FILTER FANS INSTALLATION

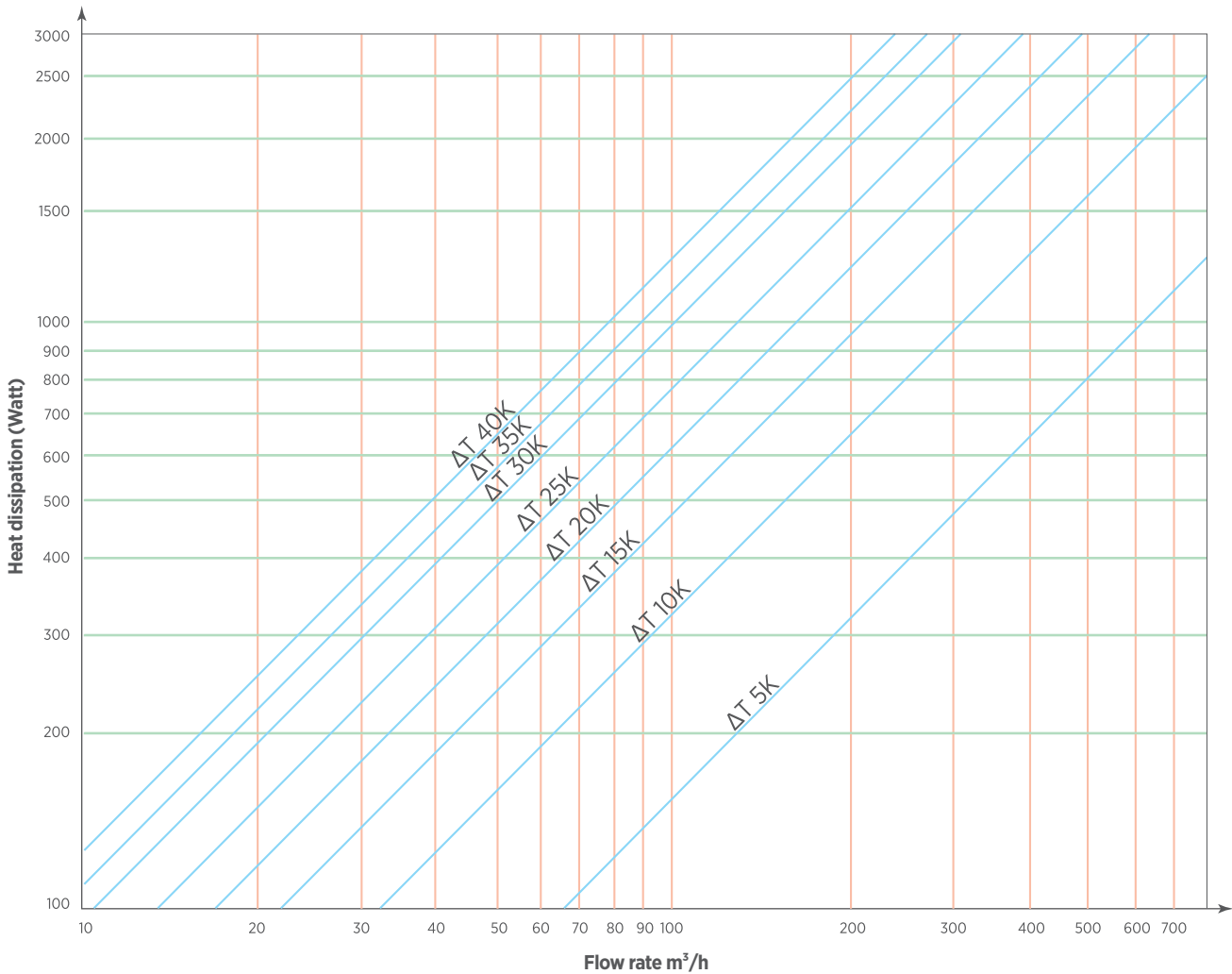

The correct air capacity for appropriate selection of the fan assembly can be determined by consulting the above diagram.

- First determine the following:
 - The thermal power dissipated by the electronic equipments.
 - The maximum temperature allowed inside the control cabinet.
 - The maximum ambient temperature foreseen outside the control cabinet.
- Calculate the ΔT as the differences between the two temperatures.
- The point at which the horizontal frame line (green) of the dissipated thermal power bisects the diagonal line (blue) of the temperature difference (ΔT) will show the vertical line (red) indicating the air capacity required for the necessary dissipation in m³/h.
- Choose the correct fan on the performance table.

Natural heat loss through the cabinet wall should be taken into account.

In order to compensate the reduction of flow rate caused by dirty filters, an increase of 20% to the obtained value is advisable.

CE All products included in this catalogue meet the essential requirements of EU directives.

In order to improve its offer, O.ERRE reserves the right to change sizes, features and design, or delete entire references of its products without notice.

Via del Commercio 1 - 25039
Travagliato (BS) - ITALY
Ph. +39 030 68 62 341
Fax +39 030 25 84 012
export@oerre.it

www.oerre.it

